



**MATERIAL**

Vacuum cup in oil-proof rubber (NBR), natural (NR), or silicone (VMQ). Support in anodised aluminium.

**STANDARD EXECUTIONS**

- **VVO-50-T-A**: oil-proof rubber.
- **VVO-50-T-N**: natural rubber.
- **VVO-50-T-S**: silicone rubber.

**FEATURES AND APPLICATIONS**

They are specifically indicated for picking up thin sheet metal or glass sheets.

The vacuum cup has a vulcanised treatment which makes it more resistant to abrasion and above all to traction forces, as well as allowing the rubber to degrade less easily following wear and making it more resistant to aggressive environmental agents.

The bellows configuration makes the vacuum cup suitable for different surfaces, even irregular ones, with imperfect flatness or inclined, allowing its use in different applications including the handling of wooden panels (chipboard or pressed) or plastic laminates.

The effective stroke of the bellows is 13 mm.

See Technical Data for vacuum cups (on page -).

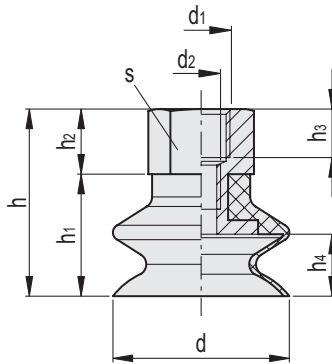

**VVO-50-T-A**

Code	Description	d	d1	d2	h	h1	h2	h3	h4	s	F* [Kg]	Volume # [cm3]	⚖️
VV.59004	VVO-50-G1/4-T-A	50	G1/4	M8	54	37	17	13	20	20	4.9	27.9	41

**VVO-50-T-N**

Code	Description	d	d1	d2	h	h1	h2	h3	h4	s	F* [Kg]	Volume # [cm3]	⚖️
VV.59005	VVO-50-G1/4-T-N	50	G1/4	M8	54	37	17	13	20	20	4.9	27.9	41

**VVO-50-T-S**

Code	Description	d	d1	d2	h	h1	h2	h3	h4	s	F* [Kg]	Volume # [cm3]	⚖️
VV.59006	VVO-50-G1/4-T-S	50	G1/4	M8	54	37	17	13	20	20	4.9	27.9	41

\* The force of the vacuum cups indicated in the table represents 1/3 of the value of the theoretical force calculated at a vacuum level of -75 KPa and a safety coefficient of 3.

# Indicates the internal geometric volume of the vacuum cup and represents the volume to be added to the entire distribution circuit for the calculation of the evacuation time, especially if multiple vacuum cups are used.