



MATERIAL

Vacuum cup in silicone rubber (VMQ).
Support in anodised aluminium.

STANDARD EXECUTIONS

- **VVN-30-S**: silicone rubber, without support.
- **VVN-30-T-S**: silicone rubber, with support.

FEATURES

They are specifically indicated for flow-pack type packaging in which the multi-bellows shape and the extremely flexible lip allow the vacuum cup to adapt to multiple types of packaged products, even fragile ones. The effective stroke of the bellows is 20 mm.

APPLICATIONS

The need to handle multiple types of products based on packaging with plastic films is widely used in many sectors including:

- food sector: packaging of snacks, biscuits, chocolate bars, baked goods, dairy products, meat and cured meats, dried fruit, cereals;
- pharmaceutical sector: for disposable products such as surgical masks;
- industrial sector: small mechanical and electronic parts;
- cosmetic industry: for packaging creams, lotions, shampoos, conditioners, and other body care products.

See Technical Data for vacuum cups (on page -).



VVN-30

VVN-30-T

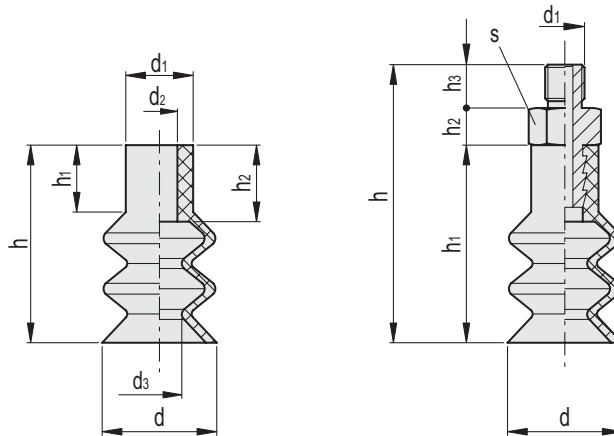

VVN-30-S

Code	Description	d	d1	d2	d3	h	h1	h2	F* [Kg]	Volume # [cm3]	⚖️
VV.58011	VVN-30-S	30	18	11	19	45	16	19	1.76	11.4	7

VVN-30-T-S

Code	Description	d	d1	h	h1	h2	h3	s	F* [Kg]	Volume # [cm3]	⚖️
VV.58016	VVN-30-G1/4-T-S	30	G1/4	67	45	8	14	17	1.76	11.4	19

* The force of the vacuum cups indicated in the table represents 1/3 of the value of the theoretical force calculated at a vacuum level of -75 KPa and a safety coefficient of 3.

Indicates the internal geometric volume of the vacuum cup and represents the volume to be added to the entire distribution circuit for the calculation of the evacuation time, especially if multiple vacuum cups are used.