



MATERIAL

Vacuum cup in oil-proof rubber (NBR), natural (NR), or silicone (VMQ).
Support in anodised aluminium.

STANDARD EXECUTIONS

- **VVM-50-A**: oil-proof rubber, without support.
- **VVM-50-N**: natural rubber, without support.
- **VVM-50-S**: silicone rubber, without support.
- **VVM-50-T-A**: oil-proof rubber, with support.
- **VVM-50-T-N**: natural rubber, with support.
- **VVM-50-T-S**: silicone rubber, with support.

FEATURES AND APPLICATIONS

They are specifically indicated for use in the food packaging sector, in particular for the handling of baked goods or confectionery products, where the multi-bellows shape is perfectly suited to the handling of even fragile packaged products. (e.g. biscuits, bread, snacks).
The adaptability to different surfaces, even irregular ones, with imperfect errors or inclined, allows these vacuum cups to also be used in different sectors where the multi-bellows shape is particularly effective.
The effective stroke of the bellows is 32 mm.
See Technical Data for vacuum cups (on page -).

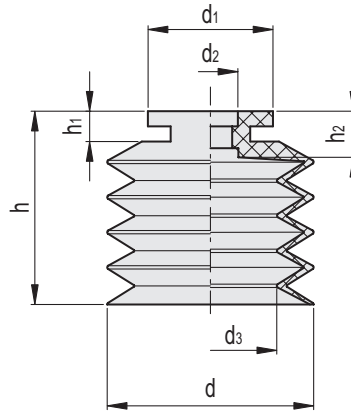

VVM-50-A

Code	Description	d	d1	d2	d3	h	h1	h2	F* [Kg]	Volume # [cm3]	⚖
VV.57019	VVM-50-A	50	27	10.5	35	53	6	10	4.9	53.3	25

VVM-50-N

Code	Description	d	d1	d2	d3	h	h1	h2	F* [Kg]	Volume # [cm3]	⚖
VV.57020	VVM-50-N	50	27	10.5	35	53	6	10	4.9	53.3	25

VVM-50-S

Code	Description	d	d1	d2	d3	h	h1	h2	F* [Kg]	Volume # [cm3]	⚖
VV.57021	VVM-50-S	50	27	10.5	35	53	6	10	4.9	53.3	25

* The force of the vacuum cups indicated in the table represents 1/3 of the value of the theoretical force calculated at a vacuum level of -75 KPa and a safety coefficient of 3.

Indicates the internal geometric volume of the vacuum cup and represents the volume to be added to the entire distribution circuit for the calculation of the evacuation time, especially if multiple vacuum cups are used.

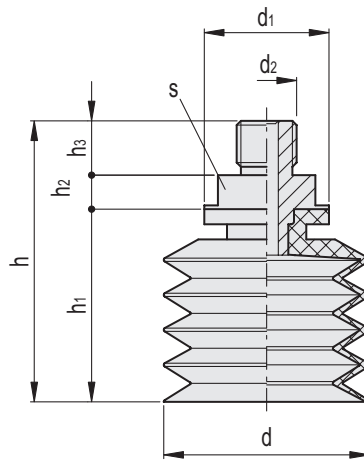

VVM-50-T-A

Code	Description	d	d1	d2	h	h1	h2	h3	s	F* [Kg]	Volume # [cm3]	⚖️
VV.57022	VVM-50-G1/4-T-A	50	27	G1/4	72.5	53	7.5	12	22	4.9	53.3	41

VVM-50-T-N

Code	Description	d	d1	d2	h	h1	h2	h3	s	F* [Kg]	Volume # [cm3]	⚖️
VV.57023	VVM-50-G1/4-T-N	50	27	G1/4	72.5	53	7.5	12	22	4.9	53.3	41

VVM-50-T-S

Code	Description	d	d1	d2	h	h1	h2	h3	s	F* [Kg]	Volume # [cm3]	⚖️
VV.57024	VVM-50-G1/4-T-S	50	27	G1/4	72.5	53	7.5	12	22	4.9	53.3	41

* The force of the vacuum cups indicated in the table represents 1/3 of the value of the theoretical force calculated at a vacuum level of -75 KPa and a safety coefficient of 3.

Indicates the internal geometric volume of the vacuum cup and represents the volume to be added to the entire distribution circuit for the calculation of the evacuation time, especially if multiple vacuum cups are used.