

MATERIAL

Vacuum cup in natural rubber (NR), or silicone rubber (VMQ).
Support in anodised aluminium.

STANDARD EXECUTIONS

- **VVL-30-55-N**: natural rubber, without support.
- **VVL-30-55-S**: silicone rubber, without support.
- **VVL-30-55-T-N**: natural rubber, with support.
- **VVL-30-55-T-S**: silicone rubber, with support.

FEATURES AND APPLICATIONS

The grooves on the surface of the vacuum cup provide a better grip even with products that have irregular or inclined surfaces.

They are specifically used in the food packaging sector where the size and the shape of the vacuum cup allow the handling of different shaped and sized packages. The adaptability to different surfaces, including irregular ones or with imperfect flatness, mean that these vacuum cups are suitable for use in various sectors including paper processing for trading cards, labels and sheets of paper and the plastic sector for laminates and small parts.

The effective stroke of the bellows is 24 mm.

See Technical Data for vacuum cups (on page -).

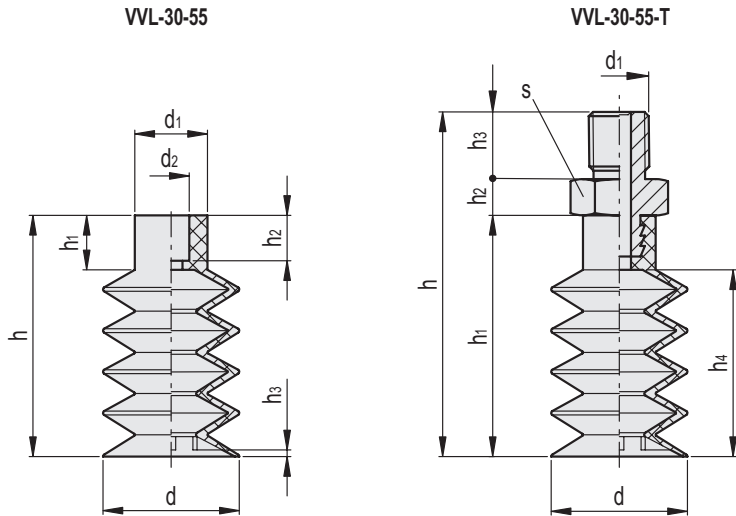

VVL-30-55-N

Code	Description	d	d1	d2	h	h1	h2	h3	F* [Kg]	Volume # [cm3]	⚖
VV.56050	VVL-30-55-N	30	16	8	55	12	10	1.5	1.76	10.6	13

VVL-30-55-S

Code	Description	d	d1	d2	h	h1	h2	h3	F* [Kg]	Volume # [cm3]	⚖
VV.56051	VVL-30-55-S	30	16	8	55	12	10	1.5	1.76	10.6	13

VVL-30-55-T-N

Code	Description	d	d1	h	h1	h2	h3	h4	s	F* [Kg]	Volume # [cm3]	⚖
VV.56053	VVL-30-55-G1/4-T-N	30	G1/4	77	55	8	14	41	17	1.76	10.6	24

VVL-30-55-T-S

Code	Description	d	d1	h	h1	h2	h3	h4	s	F* [Kg]	Volume # [cm3]	⚖
VV.56054	VVL-30-55-G1/4-T-S	30	G1/4	77	55	8	14	41	17	1.76	10.6	24

* The force of the vacuum cups indicated in the table represents 1/3 of the value of the theoretical force calculated at a vacuum level of -75 KPa and a safety coefficient of 3.

Indicates the internal geometric volume of the vacuum cup and represents the volume to be added to the entire distribution circuit for the calculation of the evacuation time, especially if multiple vacuum cups are used.