



MATERIAL

Vacuum cup in oil-proof rubber (NBR), natural (NR), or silicone (VMQ). Support in anodised aluminium.

STANDARD EXECUTIONS

- VVH-45-A: oil-proof rubber, without support.
- VVH-45-N: natural rubber, without support.
- VVH-45-S: silicone rubber, without support.
- VVH-45-T-A: oil-proof rubber, with support.
- VVH-45-T-N: natural rubber, with support.
- VVH-45-T-S: silicone rubber, with support.

FEATURES AND APPLICATIONS

They are specifically used for handling ceramic or concrete tiles with smooth or shaped surfaces.

They are used in various sectors including electronics for gripping of electrical components, food packaging and, in general, for handling products with very different technical characteristics in terms of size, materials (metal or plastic), form, and gripping surfaces (flat, slightly convex or concave).

See Technical Data for vacuum cups (on page -).

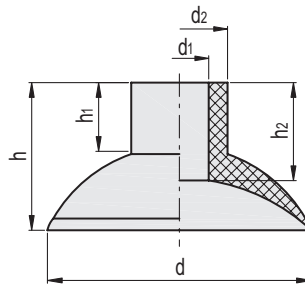

VVH-45-A

Code	Description	d	d1	d2	h	h1	h2	F* [Kg]	Volume # [cm3]	⚖
VV.52092	VVH-45-A	45	10	15	23	10	14.5	4	8.5	7

VVH-45-N

Code	Description	d	d1	d2	h	h1	h2	F* [Kg]	Volume # [cm3]	⚖
VV.52093	VVH-45-N	45	10	15	23	10	14.5	4	8.5	7

VVH-45-S

Code	Description	d	d1	d2	h	h1	h2	F* [Kg]	Volume # [cm3]	⚖
VV.52094	VVH-45-S	45	10	15	23	10	14.5	4	8.5	7

* The force of the vacuum cups indicated in the table represents 1/3 of the value of the theoretical force calculated at a vacuum level of -75 KPa and a safety coefficient of 3.

Indicates the internal geometric volume of the vacuum cup and represents the volume to be added to the entire distribution circuit for the calculation of the evacuation time, especially if multiple vacuum cups are used.

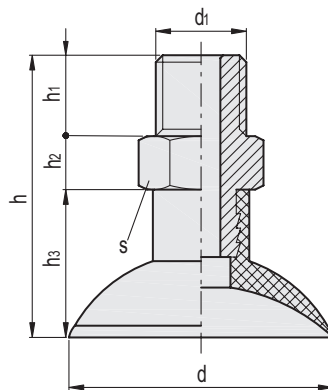

VVH-45-T-A

Code	Description	d	d1	h	h1	h2	h3	s	F* [Kg]	Volume # [cm3]	⚖️
VV.52095	VVH-45-G1/4-T-A	45	G1/4	45	14	8	23	17	4	8.5	18

VVH-45-T-N

Code	Description	d	d1	h	h1	h2	h3	s	F* [Kg]	Volume # [cm3]	⚖️
VV.52096	VVH-45-G1/4-T-N	45	G1/4	45	14	8	23	17	4	8.5	18

VVH-45-T-S

Code	Description	d	d1	h	h1	h2	h3	s	F* [Kg]	Volume # [cm3]	⚖️
VV.52097	VVH-45-G1/4-T-S	45	G1/4	45	14	8	23	17	4	8.5	18

* The force of the vacuum cups indicated in the table represents 1/3 of the value of the theoretical force calculated at a vacuum level of -75 KPa and a safety coefficient of 3.
 # Indicates the internal geometric volume of the vacuum cup and represents the volume to be added to the entire distribution circuit for the calculation of the evacuation time, especially if multiple vacuum cups are used.