



MATERIAL

Vacuum cup in oil-proof rubber (NBR), natural (NR), or silicone (VMQ).
Nickel-plated brass support.

STANDARD EXECUTIONS

- **VVH-06-A**: oil-proof rubber, without support.
- **VVH-06-N**: natural rubber, without support.
- **VVH-06-S**: silicone rubber, without support.
- **VVH-06-T-A**: oil-proof rubber, with support.
- **VVH-06-T-N**: natural rubber, with support.
- **VVH-06-T-S**: silicone rubber, with support.

FEATURES AND APPLICATIONS

They can also be used in various sectors including electronics for gripping of electrical components, food packaging, and for handling products with very different technical characteristics in terms of size, materials (metal or plastic), form, and gripping surfaces (flat, slightly convex or concave).

Due to the diameter of the support surface that is only 6 mm and the shaped support that perfectly fits the shank of the vacuum suction cup, they are also suitable for handling objects with extremely small dimensions.

See Technical Data for vacuum cups (on page -).

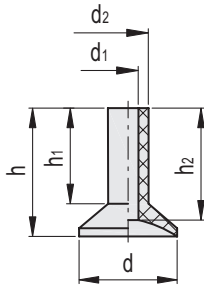

VVH-06-A

Code	Description	d	d1	d2	h	h1	h2	F* [Kg]	Volume # [mm3]	⚖️
VV.52013	VVH-06-A	6	1.5	3	8	6	7	0.07	26	1

VVH-06-N

Code	Description	d	d1	d2	h	h1	h2	F* [Kg]	Volume # [mm3]	⚖️
VV.52014	VVH-06-N	6	1.5	3	8	6	7	0.07	26	1

VVH-06-S

Code	Description	d	d1	d2	h	h1	h2	F* [Kg]	Volume # [mm3]	⚖️
VV.52015	VVH-06-S	6	1.5	3	8	6	7	0.07	26	1

* The force of the vacuum cups indicated in the table represents 1/3 of the value of the theoretical force calculated at a vacuum level of -75 KPa and a safety coefficient of 3.

Indicates the internal geometric volume of the vacuum cup and represents the volume to be added to the entire distribution circuit for the calculation of the evacuation time, especially if multiple vacuum cups are used.

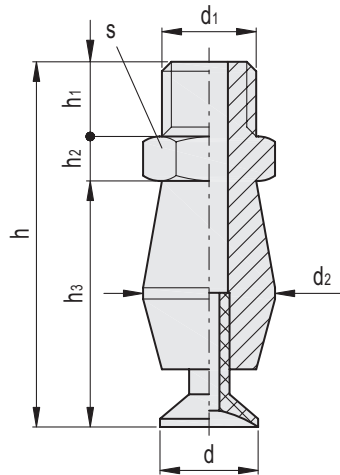

VVH-06-T-A

Code	Description	d	d1	d2	h	h1	h2	h3	s	F* [Kg]	Volume # [mm3]	⚖️
VV.52016	VVH-06-M5-T-A	6	M5	7	21.5	5	3	13.5	7	0.07	26	4

VVH-06-T-N

Code	Description	d	d1	d2	h	h1	h2	h3	s	F* [Kg]	Volume # [mm3]	⚖️
VV.52017	VVH-06-M5-T-N	6	M5	7	21.5	5	3	13.5	7	0.07	26	4

VVH-06-T-S

Code	Description	d	d1	d2	h	h1	h2	h3	s	F* [Kg]	Volume # [mm3]	⚖️
VV.52018	VVH-06-M5-T-S	6	M5	7	21.5	5	3	13.5	7	0.07	26	4

* The force of the vacuum cups indicated in the table represents 1/3 of the value of the theoretical force calculated at a vacuum level of -75 KPa and a safety coefficient of 3.

Indicates the internal geometric volume of the vacuum cup and represents the volume to be added to the entire distribution circuit for the calculation of the evacuation time, especially if multiple vacuum cups are used.