

- 1
- 2
- 3
- 4
- 5
- 6
- 7
- 8
- 9
- 10
- 11
- 12
- 13
- 14
- 15
- 16
- 17
- 18
- 19

MATERIAL

Vacuum cup in oil-proof rubber (NBR), natural (NR), or silicone (VMQ). Aluminium support.

STANDARD EXECUTIONS

- **VVG-A:** oil-proof rubber
- **VVG-N:** natural rubber
- **VVG-S:** silicone rubber

FEATURES AND APPLICATIONS

The elliptical shape makes them suitable for gripping, handling, and clipping materials or products with elongated surfaces.

The bellows shape means that when in contact with the surface of the load the vacuum cup folds quickly on itself, lifting the load from the support surface.

They are used in many sectors including paper converting (for cardboard cases or boxes), ceramic sector (tiles or bricks) and with iron or stainless steel profiles or sheets.

See Technical Data for vacuum cups (on page -).

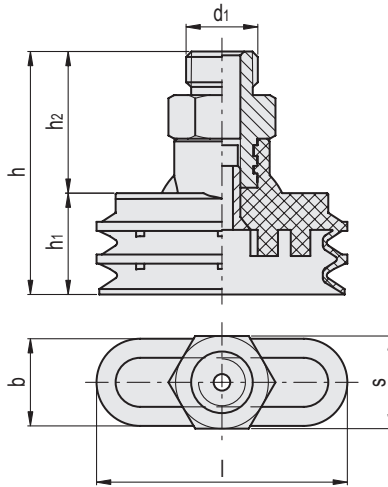

VVG-A

| Code | Description | d1 | h | h1 | h2 | b | l | s | F* [Kg] | Volume # [cm3] | ⚖️ |
|----------|--------------------|------|------|------|----|----|----|----|---------|----------------|----|
| VV.51001 | VVG-08-25-G1/8-M-A | G1/8 | 32.4 | 12.4 | 20 | 8 | 25 | 14 | 0.5 | 0.8 | 20 |
| VV.51004 | VVG-15-45-G1/4-M-A | G1/4 | 44.6 | 18.6 | 26 | 15 | 45 | 17 | 1.5 | 5 | 32 |
| VV.51007 | VVG-25-75-G1/4-M-A | G1/4 | 50.2 | 25.2 | 25 | 25 | 75 | 17 | 4.3 | 23 | 48 |

VVG-N

| Code | Description | d1 | h | h1 | h2 | b | l | s | F* [Kg] | Volume # [cm3] | ⚖️ |
|----------|--------------------|------|------|------|----|----|----|----|---------|----------------|----|
| VV.51002 | VVG-08-25-G1/8-M-N | G1/8 | 32.4 | 12.4 | 20 | 8 | 25 | 14 | 0.5 | 0.8 | 20 |
| VV.51005 | VVG-15-45-G1/4-M-N | G1/4 | 44.6 | 18.6 | 26 | 15 | 45 | 17 | 1.5 | 5 | 32 |
| VV.51008 | VVG-25-75-G1/4-M-N | G1/4 | 50.2 | 25.2 | 25 | 25 | 75 | 17 | 4.3 | 23 | 48 |

VVG-S

| Code | Description | d1 | h | h1 | h2 | b | l | s | F* [Kg] | Volume # [cm3] | ⚖️ |
|----------|--------------------|------|------|------|----|----|----|----|---------|----------------|----|
| VV.51003 | VVG-08-25-G1/8-M-S | G1/8 | 32.4 | 12.4 | 20 | 8 | 25 | 14 | 0.5 | 0.8 | 20 |
| VV.51006 | VVG-15-45-G1/4-M-S | G1/4 | 44.6 | 18.6 | 26 | 15 | 45 | 17 | 1.5 | 5 | 31 |
| VV.51009 | VVG-25-75-G1/4-M-S | G1/4 | 50.2 | 25.2 | 25 | 25 | 75 | 17 | 4.3 | 23 | 47 |

* The force of the vacuum cups indicated in the table represents 1/3 of the value of the theoretical force calculated at a vacuum level of -75 KPa and a safety coefficient of 3.

Indicates the internal geometric volume of the vacuum cup and represents the volume to be added to the entire distribution circuit for the calculation of the evacuation time, especially if multiple vacuum cups are used.