

**MATERIAL**

Vacuum cup in hydrogenated nitrile rubber (HNBR).  
Steel support.

**FEATURES**

The bellows shape of the VVC vacuum suction cups means that when in contact with the surface of the load the vacuum cup folds quickly on itself, lifting the load from the support surface.

The extreme flexibility of the gripping lip allows them to adapt to flat, concave, and convex surfaces, without any risk of deforming or breaking the objects gripped, even the thinnest ones.

This feature guarantees a safe and stable grip on the product in all conditions.

- Hardness 60÷75 Shore A;
- Operating temperature between -40 e +170 °C;
- Stain proof;
- Excellent resistance to abrasion, water and drawing oils containing chlorine.

**APPLICATIONS**

Specifically designed for use in the robot-automotive sector, particularly on surfaces such as sheet metal or glass (windshield).

Thanks to their high grip they can also be used for handling steel tubes, copper bars, marble slabs and metal parts even with irregular surfaces. See Technical Data for vacuum cups (on page -).

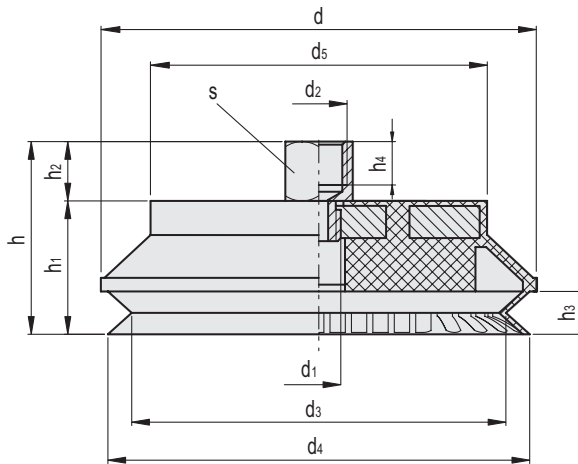

Code	Description	d	d1	d2	d3	d4	d5	h	h1	h2	h3	h4	s	F* [Kg]	Volume # [cm3]	△
VV.47001	VVC-40-G1/4-B	43	G1/4	G1/4	24	40	30	35	21	14	7	10	17	4	4.5	57
VV.47002	VVC-50-G3/8-B	53	G3/8	G3/8	34	50	40	36	21	15	7	10	22	6.2	7	78
VV.47003	VVC-60-G3/8-B	63	G3/8	G3/8	44	60	50	36	21	15	7	10	22	7.1	13.2	108
VV.47004	VVC-80-G3/8-B	83	G3/8	G3/8	64	80	70	38	23	15	9	10	22	11.1	15	206
VV.47005	VVC-100-G3/8-B	103	G3/8	G3/8	79	100	80	44	29	15	13	10	22	16	32.1	269
VV.47006	VVC-125-G3/8-B	128	G3/8	G3/8	100	125	105	47.5	32.5	15	16.5	10	22	21.9	53.5	465

\* The force of the vacuum cups indicated in the table represents 1/3 of the value of the theoretical force calculated at a vacuum level of -75 KPa and a safety coefficient of 3.

# Indicates the internal geometric volume of the vacuum cup and represents the volume to be added to the entire distribution circuit for the calculation of the evacuation time, especially if multiple vacuum cups are used.