

MATERIAL

Vacuum cup in hydrogenated nitrile rubber (HNBR).
Aluminium support.

FEATURES

The extreme flexibility of the gripping lip allows them to adapt to flat, concave, and convex surfaces, without any risk of deforming or breaking the objects gripped, even the thinnest ones.

The labyrinth moulded onto the support surface of the vacuum cup ensures a high grip with the load surface. In particular on oiled sheets, glass sheets, or wet marble, it facilitates the drainage of liquids. This feature guarantees a safe and stable grip on the product in all conditions.

- Hardness 60÷75 Shore A;
- Operating temperature between -40 e +170 °C;
- Stain proof;
- Excellent resistance to abrasion, water and drawing oils containing chlorine.

APPLICATIONS

Specifically designed for use in the robot-automotive sector, particularly on surfaces such as sheet metal or glass (windshield).

Thanks to their high grip they can also be used for handling marble slabs and metal parts even with irregular surfaces.
See Technical Data for vacuum cups (on page -).

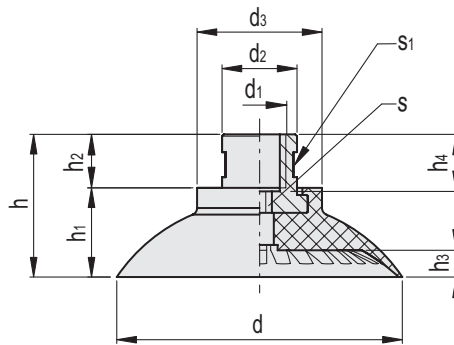

Code	Description	d	d1	d2	d3	h	h1	h2	h3	h4	s	s1	F* [Kg]	Volume # [cm3]	⚖
VV.46501	VVB-40-G1/4-B	40	G1/4	17	26	31	16	15	4	14	6	15	3.14	3.7	34
VV.46502	VVB-50-G3/8-B	50	G3/8	21	30	33	18	15	5	14	6	19	4.9	7.4	50
VV.46503	VVB-60-G3/8-B	60	G3/8	21	30	36	21	15	6	14	6	19	7	13.9	56
VV.46504	VVB-80-G3/8-B	80	G3/8	21	35	40	25	15	7.5	14	6	19	12.5	29.6	75
VV.46505	VVB-100-G3/8-B	100	G3/8	21	35	40	25	15	9.5	14	6	19	19.6	51.6	81
VV.46506	VVB-125-G3/8-B	125	G3/8	21	35	48	33	15	12.5	14	6	19	30.6	96.5	140

* The force of the vacuum cups indicated in the table represents 1/3 of the value of the theoretical force calculated at a vacuum level of -75 KPa and a safety coefficient of 3.

Indicates the internal geometric volume of the vacuum cup and represents the volume to be added to the entire distribution circuit for the calculation of the evacuation time, especially if multiple vacuum cups are used.