

MATERIAL

Vacuum cup in oil-proof rubber (NBR), natural rubber (NR), natural yellow rubber (NG), or silicone rubber (VMQ).
 Nickel-plated aluminium support.

STANDARD EXECUTIONS

- VVA-65-A: oil-proof rubber, without support.
- VVA-65-N: natural rubber, without support.
- VVA-65-NG: natural yellow rubber, without support.
- VVA-65-S: silicone rubber, without support.
- VVA-65-T-A: oil-proof rubber, with support.
- VVA-65-T-N: natural rubber, with support.
- VVA-65-T-NG: natural yellow rubber, with support.
- VVA-65-T-S: silicone rubber, with support.

FEATURES AND APPLICATIONS

They are specifically used in the paper converting sector, in particular for the handling of cardboard sheets.

The presence of the grooves on the surface of the vacuum cup allows for superior grip and a more effective grip on the object to be manipulated.

See Technical Data for vacuum cups (on page -).

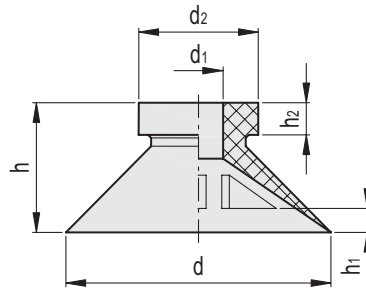

VVA-65-A

Code	Description	d	d1	d2	h	h1	h2	F* [Kg]	Volume # [cm3]	
VV.45043	VVA-65-A	65	10	25	28	5	6	8.2	21	10.5

VVA-65-N

Code	Description	d	d1	d2	h	h1	h2	F* [Kg]	Volume # [cm3]	
VV.45044	VVA-65-N	65	10	25	28	5	6	8.2	21	10.5

VVA-65-NG

Code	Description	d	d1	d2	h	h1	h2	F* [Kg]	Volume # [cm3]	
VV.45045	VVA-65-NG	65	10	25	28	5	6	8.2	21	10.5

VVA-65-S

Code	Description	d	d1	d2	h	h1	h2	F* [Kg]	Volume # [cm3]	
VV.45046	VVA-65-S	65	10	25	28	5	6	8.2	21	10.5

* The force of the vacuum cups indicated in the table represents 1/3 of the value of the theoretical force calculated at a vacuum level of -75 KPa and a safety coefficient of 3.

Indicates the internal geometric volume of the vacuum cup and represents the volume to be added to the entire distribution circuit for the calculation of the evacuation time, especially if multiple vacuum cups are used.

Vacuum components

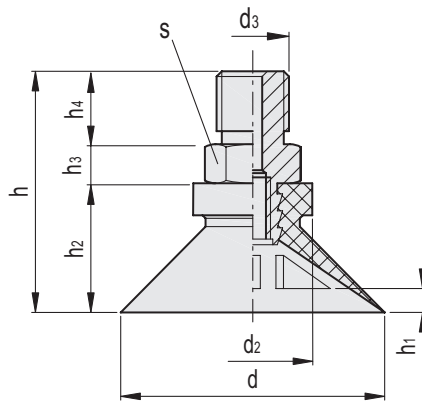

VVA-65-T-A

Code	Description	d	d2	d3	h	h1	h2	h3	h4	s	F* [Kg]	Volume # [cm3]	⚖️
VV.45047	VVA-65-G1/4-T-A	65	25	G1/4	50	5	28	8	14	17	8.2	21	26

VVA-65-T-N

Code	Description	d	d2	d3	h	h1	h2	h3	h4	s	F* [Kg]	Volume # [cm3]	⚖️
VV.45048	VVA-65-G1/4-T-N	65	25	G1/4	50	5	28	8	14	17	8.2	21	26

VVA-65-T-NG

Code	Description	d	d2	d3	h	h1	h2	h3	h4	s	F* [Kg]	Volume # [cm3]	⚖️
VV.45049	VVA-65-G1/4-T-NG	65	25	G1/4	50	5	28	8	14	17	8.2	21	26

VVA-65-T-S

Code	Description	d	d2	d3	h	h1	h2	h3	h4	s	F* [Kg]	Volume # [cm3]	⚖️
VV.45050	VVA-65-G1/4-T-S	65	25	G1/4	50	5	28	8	14	17	8.2	21	26

* The force of the vacuum cups indicated in the table represents 1/3 of the value of the theoretical force calculated at a vacuum level of -75 KPa and a safety coefficient of 3.
 # Indicates the internal geometric volume of the vacuum cup and represents the volume to be added to the entire distribution circuit for the calculation of the evacuation time, especially if multiple vacuum cups are used.

