

MATERIAL

Vacuum cup in oil-proof rubber (NBR), natural rubber (NR), or silicone rubber (VMQ).

Aluminium support.

STANDARD EXECUTIONS

- VVA-30-N: natural rubber, without support.
- VVA-30-S: silicone rubber, without support.
- VVA-30-L-N: natural rubber with high labyrinth, without support.
- VVA-30-L-S: silicone rubber with high labyrinth, without support.
- VVA-30-T-N: natural rubber, with support.
- VVA-30-T-S: silicone rubber, with support.
- VVA-30-L-T-N: natural rubber with high labyrinth, with support.
- VVA-30-L-T-S: silicone rubber with high labyrinth, with support.

FEATURES AND APPLICATIONS

They are widely used in the packaging sector, in particular in packaging using plastic films and in the paper converting sector for the handling of sheets of paper.

The labyrinth moulded onto the support surface of the vacuum cup ensures a more effective grip on the product to be handled; in particular, the notches allow even distribution of the vacuum on the surface of the product, preventing the packaging sheet or bag from being sucked into the vacuum cup and becoming deformed.

The high labyrinth (L) also allows for even higher grip values between the vacuum cup and the product.

See Technical Data for vacuum cups (on page -).

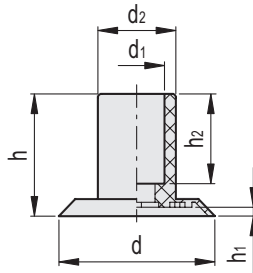

VVA-30-N

Code	Description	d	d1	d2	h	h1	h2	F* [Kg]	Volume # [cm3]	⚖
VV.45023	VVA-30-N	30	11	15	24	3	16	1.76	2.2	3

VVA-30-S

Code	Description	d	d1	d2	h	h1	h2	F* [Kg]	Volume # [cm3]	⚖
VV.45024	VVA-30-S	30	11	15	24	3	16	1.76	2.2	3

VVA-30-L-N

Code	Description	d	d1	d2	h	h1	h2	F* [Kg]	Volume # [cm3]	⚖
VV.45027	VVA-30-L-N	30	11	15	24	1.5	16	1.76	1.8	3

VVA-30-L-S

Code	Description	d	d1	d2	h	h1	h2	F* [Kg]	Volume # [cm3]	⚖
VV.45028	VVA-30-L-S	30	11	15	24	1.5	16	1.76	1.8	3

* The force of the vacuum cups indicated in the table represents 1/3 of the value of the theoretical force calculated at a vacuum level of -75 KPa and a safety coefficient of 3.

Indicates the internal geometric volume of the vacuum cup and represents the volume to be added to the entire distribution circuit for the calculation of the evacuation time, especially if multiple vacuum cups are used.

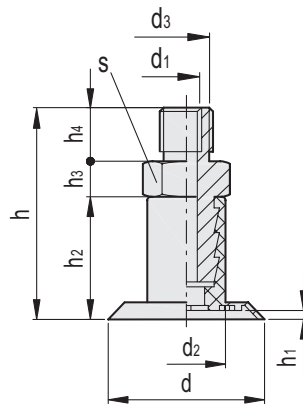

VVA-30-T-N

Code	Description	d	d1	d2	d3	h	h1	h2	h3	h4	s	F* [Kg]	Volume # [cm3]	⚖️
VV.45025	VVA-30-G1/4-T-N	30	M8	15	G1/4	46	3	24	8	14	17	1.76	2.2	16

VVA-30-T-S

Code	Description	d	d1	d2	d3	h	h1	h2	h3	h4	s	F* [Kg]	Volume # [cm3]	⚖️
VV.45026	VVA-30-G1/4-T-S	30	M8	15	G1/4	46	3	24	8	14	17	1.76	2.2	16

VVA-30-L-T-N

Code	Description	d	d1	d2	d3	h	h1	h2	h3	h4	s	F* [Kg]	Volume # [cm3]	⚖️
VV.45029	VVA-30-G1/4-L-T-N	30	M8	15	G1/4	46	1.5	24	8	14	17	1.76	1.8	16

VVA-30-L-T-S

Code	Description	d	d1	d2	d3	h	h1	h2	h3	h4	s	F* [Kg]	Volume # [cm3]	⚖️
VV.45030	VVA-30-G1/4-L-T-S	30	M8	15	G1/4	46	1.5	24	8	14	17	1.76	1.8	16

* The force of the vacuum cups indicated in the table represents 1/3 of the value of the theoretical force calculated at a vacuum level of -75 KPa and a safety coefficient of 3.
 # Indicates the internal geometric volume of the vacuum cup and represents the volume to be added to the entire distribution circuit for the calculation of the evacuation time, especially if multiple vacuum cups are used.

