



- 1
- 2
- 3
- 4
- 5
- 6
- 7
- 8
- 9
- 10
- 11
- 12
- 13
- 14
- 15
- 16
- 17
- 18

MATERIAL

Glass-fibre reinforced polyamide based (PA) technopolymer, black colour, matte finish.

STANDARD EXECUTIONS

- **VTT-HL-AZ**: Zinc-plated hexagonal shank, threaded blind hole.
- **VTT-HL-SST**: AISI 304 stainless steel hexagonal shank, threaded blind hole.

FEATURES AND APPLICATIONS

The hexagonal shank allows the handwheel to be tightened with a spanner.

The three-lobe shape with large recesses is particularly ergonomic also for smaller knobs, ensuring an effective grip even with work gloves.

The full section design without rear cavities prevents the deposit of unsanitary residues, ensuring maximum cleanability and making the product particularly suitable for applications on machines and equipment subject to frequent cleaning with water or steam jets.



ELESA Original design

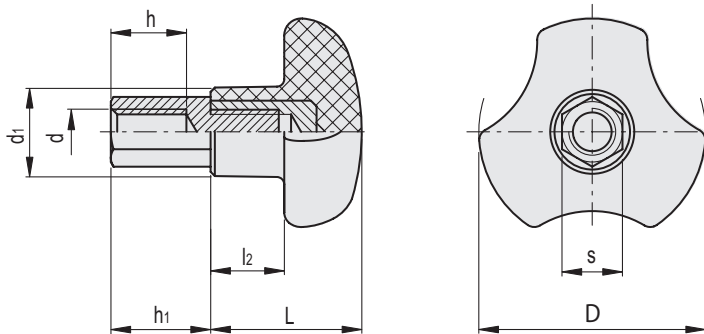

Conversion Table	
1 mm = 0.039 inch	
D	
mm	inch
40	1.57
50	1.97
60	2.36

VTT-HL-AZ



Code	Description	D	d6H	s	L	d1	l2	h	h1	⚖
196336	VTT.40-HL-AZ-M8	40	M8	13	27	16	13.5	12	18	34
196466	VTT.50-HL-AZ-M10	50	M10	16	30	19	15	15	22	51
196502	VTT.60-HL-AZ-M12	60	M12	16	34	22.5	18	18	26	77

VTT-HL-SST



Code	Description	D	d6H	s	L	d1	l2	h	h1	⚖
196346	VTT.40-HL-SST-M8	40	M8	13	27	16	13.5	12	18	34
196476	VTT.50-HL-SST-M10	50	M10	16	30	19	15	15	22	51
196512	VTT.60-HL-SST-M12	60	M12	16	34	22.5	18	18	26	77

Clamping elements