

MATERIAL

- Glass-fibre reinforced polyamide based (PA) technopolymer knob, black colour, matte finish.
- AISI 303 stainless steel threaded stud, spherical end.
- Acetal resin based (POM) technopolymer thrust pad, black colour, matte finish, supplied not assembled.

FEATURES AND APPLICATIONS

The VC.692-SST-p-SV knobs allow forceful locking of a component avoiding, thanks to the thrust pad, direct contact of the stud with the surface to be locked.

The metal insert in AISI 303 stainless steel can be used in sectors where corrosion resistant materials are required.



Application example

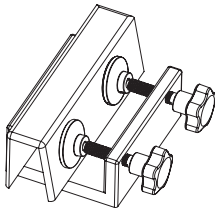

ELESA Original design

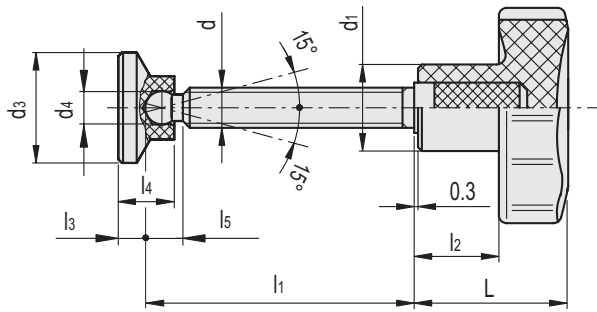
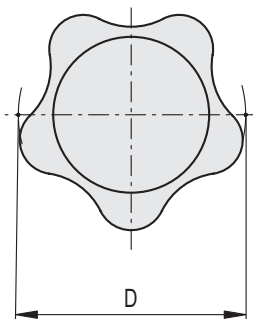

**Conversion Table**  
1 mm = 0.039 inch

D	
mm	inch
25	0.98
32	1.25

Code	Description	D	d6g	L	d1	d3	d4	l1	l2	l3	l4	l5	△
164001	VC.692/25 SST-p-M6x25-SV15	25	M6	20	12	15	4.5	25	10	3.5	7.5	5	16
164003	VC.692/25 SST-p-M6x35-SV15	25	M6	20	12	15	4.5	35	10	3.5	7.5	5	18
164005	VC.692/25 SST-p-M6x45-SV15	25	M6	20	12	15	4.5	45	10	3.5	7.5	5	19
164011	VC.692/25-SST-p-M6x25-SV18	25	M6	20	12	18	4.5	25	10	4	9	6	20
164013	VC.692/25-SST-p-M6x35-SV18	25	M6	20	12	18	4.5	35	10	4	9	6	21
164015	VC.692/25-SST-p-M6x45-SV18	25	M6	20	12	18	4.5	45	10	4	9	6	23
164021	VC.692/25-SST-p-M6x25-SV21	25	M6	20	12	21	4.5	25	10	5	10	6	20
164023	VC.692/25-SST-p-M6x35-SV21	25	M6	20	12	21	4.5	35	10	5	10	6	22
164025	VC.692/25-SST-p-M6x45-SV21	25	M6	20	12	21	4.5	45	10	5	10	6	24
164101	VC.692/32 SST-p-M6x25-SV15	32	M6	22.5	14	15	4.5	25	12.5	3.5	7.5	5	20
164103	VC.692/32 SST-p-M6x35-SV15	32	M6	22.5	14	15	4.5	35	12.5	3.5	7.5	5	21
164105	VC.692/32 SST-p-M6x45-SV15	32	M6	22.5	14	15	4.5	45	12.5	3.5	7.5	5	21
164081	VC.692/32-SST-p-M6x25-SV18	32	M6	22.5	14	18	4.5	25	12.5	4	9	6	20
164083	VC.692/32-SST-p-M6x35-SV18	32	M6	22.5	14	18	4.5	35	12.5	4	9	6	21
164085	VC.692/32-SST-p-M6x45-SV18	32	M6	22.5	14	18	4.5	45	12.5	4	9	6	21
164091	VC.692/32-SST-p-M6x25-SV21	32	M6	22.5	14	21	4.5	25	12.5	5	10	6	21
164093	VC.692/32-SST-p-M6x35-SV21	32	M6	22.5	14	21	4.5	35	12.5	5	10	6	22
164095	VC.692/32-SST-p-M6x45-SV21	32	M6	22.5	14	21	4.5	45	12.5	5	10	6	22
164111	VC.692/32-SST-p-M8x30-SV18	32	M8	22.5	14	18	6	30	12.5	4	9	6	34
164113	VC.692/32-SST-p-M8x40-SV18	32	M8	22.5	14	18	6	40	12.5	4	9	6	37
164115	VC.692/32-SST-p-M8x50-SV18	32	M8	22.5	14	18	6	50	12.5	4	9	6	32
164121	VC.692/32-SST-p-M8x30-SV21	32	M8	22.5	14	21	6	30	12.5	5	10	6	35
164123	VC.692/32-SST-p-M8x40-SV21	32	M8	22.5	14	21	6	40	12.5	5	10	6	38
164125	VC.692/32-SST-p-M8x50-SV21	32	M8	22.5	14	21	6	50	12.5	5	10	6	33

Conversion Table	
1 mm = 0.039 inch	
D	
mm	inch
40	1.56
50	1.95
60	2.34

INOX STAINLESS STEEL METRIC

Code	Description	D	d6g	L	d1	d3	d4	l1	l2	l3	l4	l5	⚖
164131	VC.692/32-SST-p-M8x30-SV25	32	M8	22.5	14	25	6	30	12.5	5.5	10.5	6	35
164133	VC.692/32-SST-p-M8x40-SV25	32	M8	22.5	14	25	6	40	12.5	5.5	10.5	6	38
164135	VC.692/32-SST-p-M8x50-SV25	32	M8	22.5	14	25	6	50	12.5	5.5	10.5	6	33
164141	VC.692/32-SST-p-M8x30-SV32	32	M8	22.5	14	32	6	30	12.5	6	11	6	36
164143	VC.692/32-SST-p-M8x40-SV32	32	M8	22.5	14	32	6	40	12.5	6	11	6	39
164145	VC.692/32-SST-p-M8x50-SV32	32	M8	22.5	14	32	6	50	12.5	6	11	6	34
164151	VC.692/32-SST-p-M8x30-SV40	32	M8	22.5	14	40	6	30	12.5	8	13	6	36
164153	VC.692/32-SST-p-M8x40-SV40	32	M8	22.5	14	40	6	40	12.5	8	13	6	39
164155	VC.692/32-SST-p-M8x50-SV40	32	M8	22.5	14	40	6	50	12.5	8	13	6	34
164201	VC.692/40-SST-p-M8x30-SV18	40	M8	26	15	18	6	30	14	4	9	6	35
164203	VC.692/40-SST-p-M8x40-SV18	40	M8	26	15	18	6	40	14	4	9	6	38
164205	VC.692/40-SST-p-M8x50-SV18	40	M8	26	15	18	6	50	14	4	9	6	38
164211	VC.692/40-SST-p-M8x30-SV21	40	M8	26	15	21	6	30	14	5	10	6	36
164213	VC.692/40-SST-p-M8x40-SV21	40	M8	26	15	21	6	40	14	5	10	6	39
164215	VC.692/40-SST-p-M8x50-SV21	40	M8	26	15	21	6	50	14	5	10	6	39
164221	VC.692/40-SST-p-M8x30-SV25	40	M8	26	15	25	6	30	14	5.5	10.5	6	36
164223	VC.692/40-SST-p-M8x40-SV25	40	M8	26	15	25	6	40	14	5.5	10.5	6	39
164225	VC.692/40-SST-p-M8x50-SV25	40	M8	26	15	25	6	50	14	5.5	10.5	6	39
164231	VC.692/40-SST-p-M8x30-SV32	40	M8	26	15	32	6	30	14	6	11	6	37
164233	VC.692/40-SST-p-M8x40-SV32	40	M8	26	15	32	6	40	14	6	11	6	40
164235	VC.692/40-SST-p-M8x50-SV32	40	M8	26	15	32	6	50	14	6	11	6	40
164241	VC.692/40-SST-p-M8x30-SV40	40	M8	26	15	40	6	30	14	8	13	6	37
164243	VC.692/40-SST-p-M8x40-SV40	40	M8	26	15	40	6	40	14	8	13	6	40
164245	VC.692/40-SST-p-M8x50-SV40	40	M8	26	15	40	6	50	14	8	13	6	40
164251	VC.692/40 SST-p-M10x35-SV21	40	M10	26	15	21	8	35	14	4	10	7.5	46
164253	VC.692/40 SST-p-M10x45-SV21	40	M10	26	15	21	8	45	14	4	10	7.5	52
164255	VC.692/40 SST-p-M10x55-SV21	40	M10	26	15	21	8	55	14	4	10	7.5	56
164261	VC.692/40 SST-p-M10x35-SV25	40	M10	26	15	25	8	35	14	4.5	10.5	7.5	46
164263	VC.692/40 SST-p-M10x45-SV25	40	M10	26	15	25	8	45	14	4.5	10.5	7.5	52
164265	VC.692/40 SST-p-M10x55-SV25	40	M10	26	15	25	8	55	14	4.5	10.5	7.5	56
164271	VC.692/40 SST-p-M10x35-SV32	40	M10	26	15	32	8	35	14	5	11	7.5	50
164273	VC.692/40 SST-p-M10x45-SV32	40	M10	26	15	32	8	45	14	5	11	7.5	56
164275	VC.692/40 SST-p-M10x55-SV32	40	M10	26	15	32	8	55	14	5	11	7.5	60
164281	VC.692/40 SST-p-M10x35-SV40	40	M10	26	15	40	8	35	14	7	13	7.5	50
164283	VC.692/40 SST-p-M10x45-SV40	40	M10	26	15	40	8	45	14	7	13	7.5	56
164285	VC.692/40 SST-p-M10x55-SV40	40	M10	26	15	40	8	55	14	7	13	7.5	60
164301	VC.692/50-SST-p-M10x35-SV21	50	M10	31	18	21	8	35	17	4	10	7.5	62
164303	VC.692/50-SST-p-M10x45-SV21	50	M10	31	18	21	8	45	17	4	10	7.5	68
164305	VC.692/50-SST-p-M10x55-SV21	50	M10	31	18	21	8	55	17	4	10	7.5	72
164311	VC.692/50-SST-p-M10x35-SV25	50	M10	31	18	25	8	35	17	4.5	10.5	7.5	62
164313	VC.692/50-SST-p-M10x45-SV25	50	M10	31	18	25	8	45	17	4.5	10.5	7.5	68
164315	VC.692/50-SST-p-M10x55-SV25	50	M10	31	18	25	8	55	17	4.5	10.5	7.5	72
164321	VC.692/50-SST-p-M10x35-SV32	50	M10	31	18	32	8	35	17	5	11	7.5	66
164323	VC.692/50-SST-p-M10x45-SV32	50	M10	31	18	32	8	45	17	5	11	7.5	72
164325	VC.692/50-SST-p-M10x55-SV32	50	M10	31	18	32	8	55	17	5	11	7.5	76
164331	VC.692/50-SST-p-M10x35-SV40	50	M10	31	18	40	8	35	17	7	13	7.5	66
164333	VC.692/50-SST-p-M10x45-SV40	50	M10	31	18	40	8	45	17	7	13	7.5	72
164335	VC.692/50-SST-p-M10x55-SV40	50	M10	31	18	40	8	55	17	7	13	7.5	76
164401	VC.692/60-SST-p-M12x40-SV21	60	M12	36.5	21	21	10	40	21	3.5	10	8.5	170
164403	VC.692/60-SST-p-M12x60-SV21	60	M12	36.5	21	21	10	60	21	3.5	10	8.5	180
164411	VC.692/60-SST-p-M12x40-SV25	60	M12	36.5	21	25	10	40	21	3.5	10.5	8.5	170
164413	VC.692/60-SST-p-M12x60-SV25	60	M12	36.5	21	25	10	60	21	3.5	10.5	8.5	180
164421	VC.692/60-SST-p-M12x40-SV32	60	M12	36.5	21	32	10	40	21	4	11	8.5	170
164423	VC.692/60-SST-p-M12x60-SV32	60	M12	36.5	21	32	10	60	21	4	11	8.5	180
164431	VC.692/60-SST-p-M12x40-SV40	60	M12	36.5	21	40	10	40	21	6	13	8.5	170
164433	VC.692/60-SST-p-M12x60-SV40	60	M12	36.5	21	40	10	60	21	6	13	8.5	180

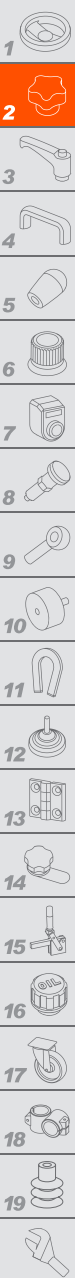

Clamping elements