

- 1
- 2
- 3
- 4
- 5
- 6
- 7
- 8
- 9
- 10
- 11
- 12
- 13
- 14
- 15
- 16
- 17
- 18
- 19

MATERIAL

Glass-fibre reinforced polyamide based (PA) technopolymer, black colour, matte finish.
Elastic fork in acetal based technopolymer (POM), black colour.

PACKING RING

NBR synthetic rubber O-Ring.
In addition to guaranteeing the OR-ring retention, the seat for the housing allows an optimal seal even with minimum tightening torques.

MAXIMUM CONTINUOUS WORKING TEMPERATURE

The maximum continuous working temperature that can be reached inside the tank is 100°C.
The maximum continuous working temperature of the external environment must not exceed 60°C.

FEATURES AND APPLICATIONS

Suitable for use when it is necessary to avoid the loss of the cap.
The elastic fork, housed in the special groove of the cap, can rotate freely.

TECHNICAL DATA

In laboratory tests carried out with mineral oil type CB68 (according to ISO 3498) at 23°C for a limited period of time, the values of pressure resistance were much higher than 100 bar.
In any case, we suggest to check the suitability of the product with regard to the fluid nature, operating temperature and application type under the actual working conditions.

SPECIAL EXECUTIONS ON REQUEST

- CT-S (see page -) technopolymer and stainless steel ball chains.
- GN 111 (see page -) stainless steel and brass ball chains.
- CV-T (see page -) polyethylene and stainless steel retaining cables.
- GN 111.2 (see page -) stainless steel retaining cables.
- GN 111.4 (see page -) polyurethane and stainless steel spiral retaining cables.



ELESA Original design

Conversion Table 1 mm = 0.039 inch	
D	
mm	inch
32	1.26
37	1.46
44	1.73

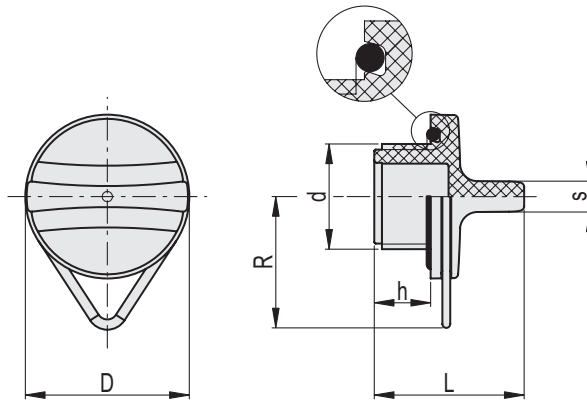

METRIC **BSP**

Code	Description	d	h	s	D	L	R	ΔΔ
158237	THR.1/2-RC	G 1/2	11	4	32	29	26	10
158238	THR.3/4-RC	G 3/4	12	5	37	32.5	28.5	18
158239	THR.1-RC	G 1	13	6	44	36	32	25