

- 1
- 2
- 3
- 4
- 5
- 6
- 7
- 8
- 9
- 10
- 11
- 12
- 13
- 14
- 15
- 16
- 17
- 18
- 19

MATERIAL

Glass-fibre reinforced polyamide based (PA) technopolymer, RAL 9005 (C9) black colour or grey RAL 7040 (C33) colour, matte finish.

FEATURES AND APPLICATIONS

The double ball joint is designed to be mounted on TCC clamps. Two bushings with spherical seats must be used for each double joint TCC-SJA (see page -), not included in the supply.

TECHNICAL DATA

The resistance values shown in the table were measured during laboratory tests at ambient temperature with the screws tightened to the recommended torque of 5 Nm.

Each ball joint can be freely rotated and tilted to a maximum of +/-30 degrees.

ASSEMBLY INSTRUCTIONS (FIG. 1)

1. Force the ball joint into one end of the bushing and repeat the same operation for the other joint.
 2. After loosening the clamping screws, insert the sleeves into them until they snap in.
 3. Turn the joints to the desired position.
 4. Tighten the screws of the clamps.
- We recommend loosening the clamping screws when it is necessary to change the position of the joints.



Fig. 1

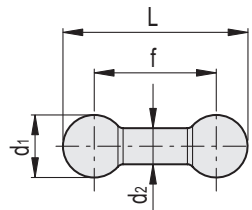
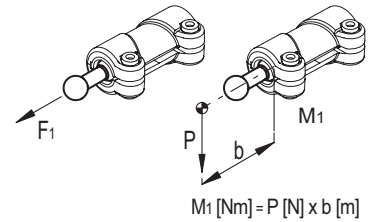
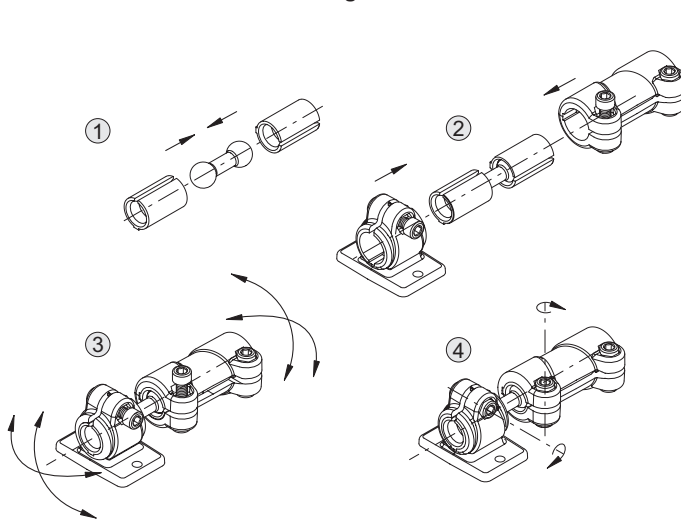

C9 RAL9005
 C33 RAL7040

METRIC

Conversion Table	
1 mm = 0.039 inch	
L	
mm	inch
41	1.60

Code	Description	L	d1	d2	f	F1* [N]	M1** [Nm]	⚖️
600163-C9	TCC-SJD-18-S14-C9	41	14	8	27	800	3	6
600163-C33	TCC-SJD-18-S14-C33	41	14	8	27	800	3	6

* Pull-out resistance of the joint
 ** Bending resistance of the joint for slipping