

- 1
- 2
- 3
- 4
- 5
- 6
- 7
- 8
- 9
- 10
- 11
- 12
- 13
- 14
- 15
- 16
- 17
- 18
- 19

BRACKET

Glass-fibre reinforced polyamide based (PA) technopolymer, black colour, matte finish.

CLAMPING HANDWHEEL

Glass-fibre reinforced technopolymer, black colour, matte finish.

EYE SCREW AND WASHER

AISI 304 stainless steel.

BOSS

Hexagonal in nickel-plated brass for tightening by means of a key, threaded hole.

FEATURES AND APPLICATIONS

Particularly suitable when a linear positioning of the guide rail is required.

The vertical or horizontal positioning of the eye screw improves the assembly where necessary. Maximum tightening torque for screw assembly 39 Nm.

ACCESSORIES ON REQUEST

DSG: spacer for guide rail bracket, in glass-fibre reinforced technopolymer, black colour, matte finish.

ASSEMBLY INSTRUCTION

- Fit the guide rail bracket (Fig. 1).
- Insert the washer into the eye screw and screw either the knob or the nut (Fig. 2).
- Insert the eye in its housing either in the horizontal or vertical position (Fig. 3).
- Insert the guide pin in its clamping hole, set the linear positioning and then fasten (Fig. 4).

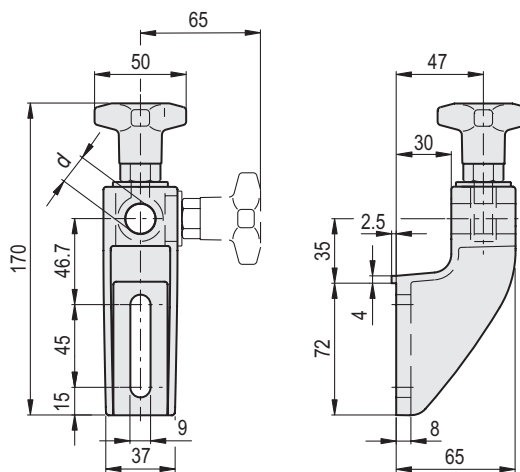
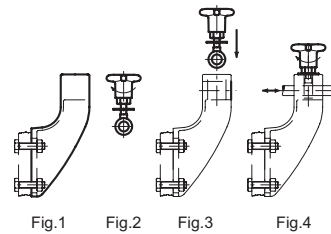

Code	Description	d	△
419701	SPFS.V-12	12	179
419702	SPFS.V-14	14	179
419703	SPFS.V-16	16	179