

- 1
- 2
- 3
- 4
- 5
- 6
- 7
- 8
- 9
- 10
- 11
- 12
- 13
- 14
- 15
- 16
- 17
- 18
- 19

MATERIAL

- Cover: steel sheet, with chrome plating superficial treatment.
- Flange: zinc-plated steel sheet.
- Bayonet and flange with bayonet: zinc-plated steel sheet.

PACKING RINGS

Three flat packing rings in NBR synthetic rubber.

RING-SHAPED AIR FILTER

Tech-foam 10 µ or 40 µ.

FILTER SETTING SPRING

Zinc-plated steel.

FILTRATION BASKET

Electro-galvanized steel or polypropylene-based technopolymer (PP), black colour.

SAFETY CHAIN (ONLY FOR SMN.80-BA)

Brass

STANDARD EXECUTIONS

- **SMN-BA-F10-FRB+CM**: filtration fineness 10 µ, steel basket.
- **SMN-BA-F40-FRB+CM**: filtration fineness 40 µ, steel basket.
- **SMN-BA-F10-FRB+C**: filtration fineness 10 µ, technopolymer basket.
- **SMN-BA-F40-FRB+C**: filtration fineness 40 µ, technopolymer basket.

MOUNTING

- SMN.46: by means of three glossy zinc-plated steel screws with screwdriver slot head M5x12, supplied.
- SMN.80: by means of six glossy zinc-plated steel screws with screwdriver slot head M5x12, supplied.

MAXIMUM CONTINUOUS WORKING TEMPERATURE

100°C.

TECHNICAL DATA

Air flow rate for the different executions of breather caps can be obtained from the diagram on the basis of the difference of air pressure inside and outside the reservoir. Tests carried out without filtration basket.



Drilling templates

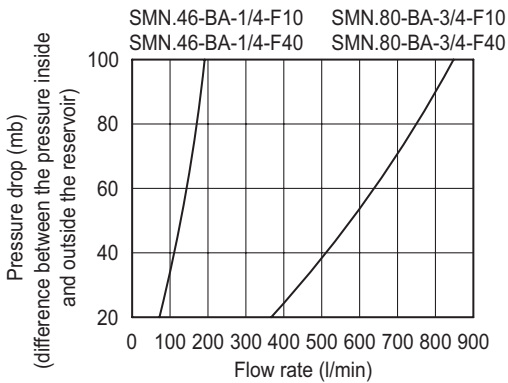
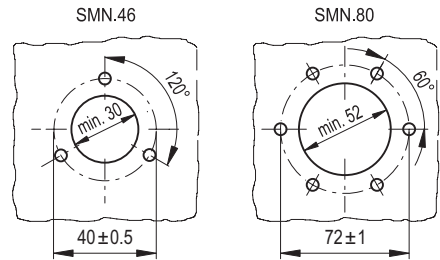

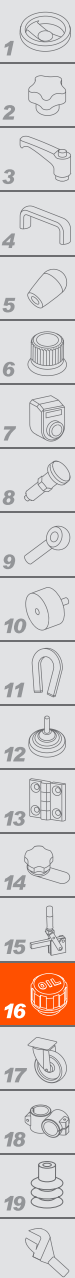

Conversion Table 1 mm = 0.039 inch	
D	
mm	inch
47	1.83
81	3.16

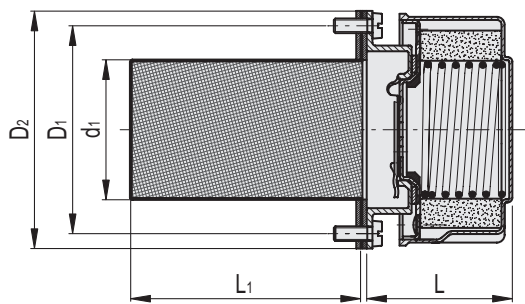
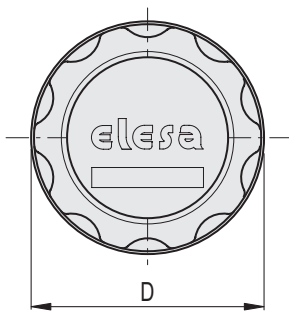

SMN-BA-F10-FRB+CM

METRIC

Code	Description	D	D1	D2	L	L1	d1	⚖️
156835	SMN.46-BA-F10-FRB+CM	47	40	52	44	66	27	112
156885	SMN.80-BA-F10-FRB+CM	81	72	83	55	80	49	375

SMN-BA-F40-FRB+CM

Code	Description	D	D1	D2	L	L1	d1	⚖️
156836	SMN.46-BA-F40-FRB+CM	47	40	52	44	66	27	113
156886	SMN.80-BA-F40-FRB+CM	81	72	83	55	80	49	375

SMN-BA-F10-FRB+C

METRIC

Code	Description	D	D1	D2	L	L1	d1	⚖️
156888	SMN.80-BA-F10-FRB+C	81	72	83	55	99	49	375

SMN-BA-F40-FRB+C

Code	Description	D	D1	D2	L	L1	d1	⚖️
156889	SMN.80-BA-F40-FRB+C	81	72	83	55	99	49	375