



MATERIAL

Zinc alloy housing with epoxy resin coating, matte finish, RAL 9005 (C9) black or RAL 9006 (C8) grey colour.

MAGNET

(NdFeB) Neodymium- iron-boron, for temperatures up to 80°C. Thermoplastic elastomer coating (TPE), black colour.

Hardness 80 Shore A.

- **T** index: upper position.

- **L** index: lateral position.

See magnets technical data.

STRIKER PLATE

Zinc-plated steel.

- **FT** index: flat shape with pass-through holes for countersunk-head screws.

- **SL** index: L-shape with slotted pass-through holes for cylinder head screws.

- **ZSL** index: Z-shape with slotted pass-through holes for cylinder head screws.

STANDARD EXECUTIONS

Body with magnet, without striker plate.

- **RMMC-A1**: with pass-through holes for cylinder head screws.

- **RMMC-A2**: with slotted pass-through holes for cylinder head screws.

Body with flat striker plate.

- **RMMC-A1-FT**: with pass-through holes for cylinder head screws.

- **RMMC-A2-FT**: with slotted pass-through holes for cylinder head screws.

Body with L-shape striker plate.

- **RMMC-A1-SL**: with pass-through holes for cylinder head screws.

- **RMMC-A2-SL**: with slotted pass-through holes for cylinder head screws.

Body with Z-shape striker plate.

- **RMMC-A1-ZSL**: with pass-through holes for cylinder head screws.

- **RMMC-A2-ZSL**: with slotted pass-through holes for cylinder head screws.

FEATURES AND APPLICATIONS

RMMC magnetic locks are compact components that allow the closing of hatches, doors, and sliding doors. The rubber-coated magnetic surface reduces noise and prevents accidental scratches on sensitive surfaces.

The slotted pass-through holes allow adjustment of the magnetic body and the strikers during installation.

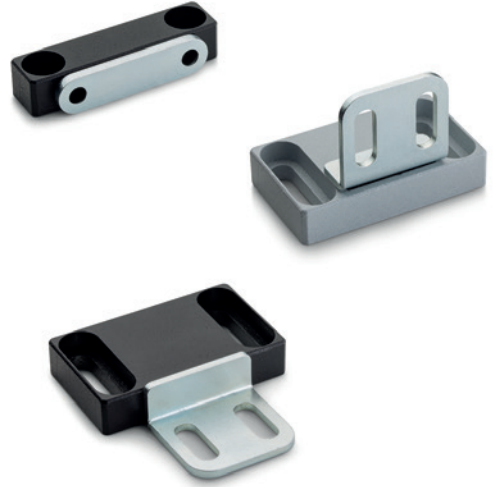

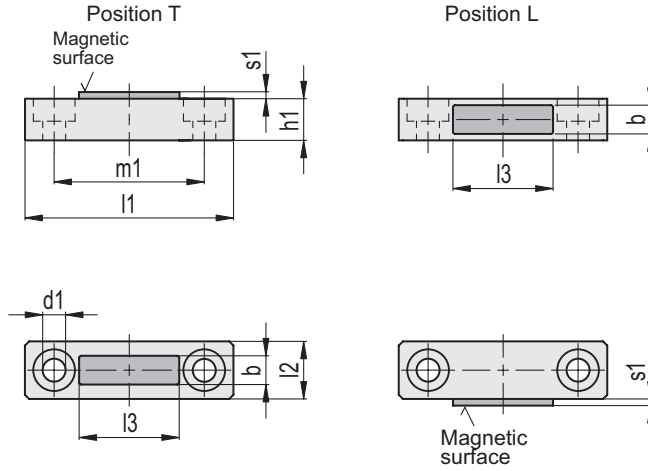

RMMC-A1

METRIC

Code	Description	b	h1	d1	l1	l2	l3	m1	s1	Nominal adhesive forces* [N]	⚖️
502221	RMMC-ND-A1-T-C9	7	10	5.5	50	12	24	38	0.5	30	35
502222	RMMC-ND-A1-L-C9	7	10	5.5	50	12	24	38	0.5	30	35
502223	RMMC-ND-A1-T-C8	7	10	5.5	50	12	24	38	0.5	30	35
502224	RMMC-ND-A1-L-C8	7	10	5.5	50	12	24	38	0.5	30	35

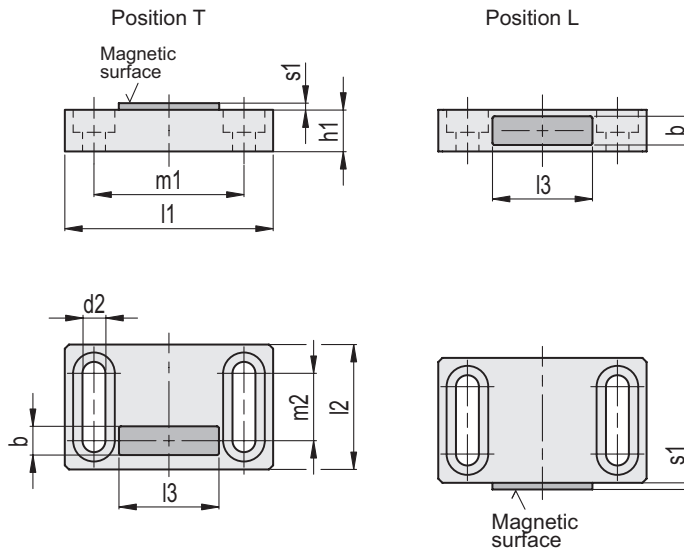

RMMC-A2

METRIC

Code	Description	b	h1	d2	l1	l2	l3	m1	m2	s1	Nominal adhesive forces* [N]	⚖️
502226	RMMC-ND-A2-T-C9	7	10	5.5	50	30	24	38	18	0.5	30	55
502227	RMMC-ND-A2-L-C9	7	10	5.5	50	30	24	38	18	0.5	30	55
502228	RMMC-ND-A2-T-C8	7	10	5.5	50	30	24	38	18	0.5	30	55
502229	RMMC-ND-A2-L-C8	7	10	5.5	50	30	24	38	18	0.5	30	55

* The values of the nominal adhesive forces are approximate and refer to magnetic properties observed on laboratory samples.



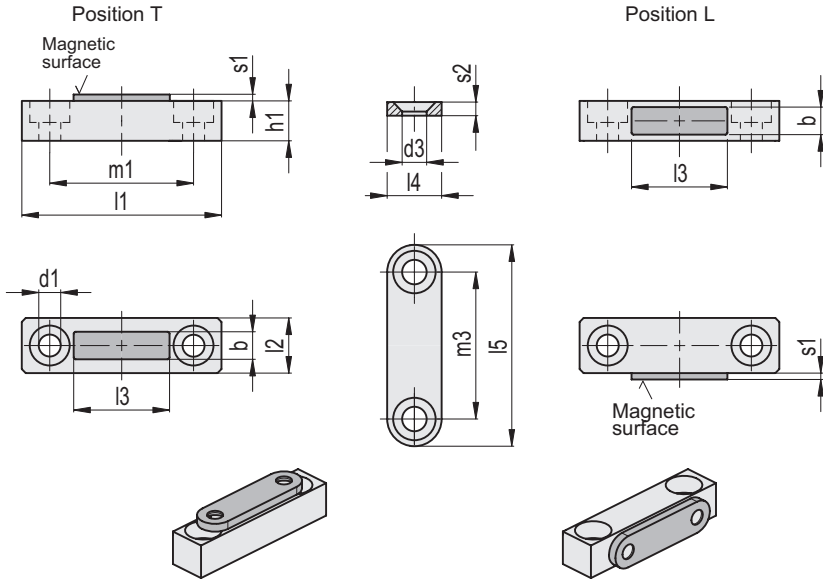

METRIC

RMMC-A1-FT

Code	Description	b	h1	d1	d3	l1	l2	l3	l4	l5	m1	m3	s1	s2	Nominal adhesive forces* [N]	⚖️
502231-C9	RMMC-ND-A1-T-FT-C9	7	10	5.5	4.5	50	12	24	10	40	38	30	0.5	2.5	30	42
502238-C9	RMMC-ND-A1-L-FT-C9	7	10	5.5	4.5	50	12	24	10	40	38	30	0.5	2.5	30	42
502245-C8	RMMC-ND-A1-T-FT-C8	7	10	5.5	4.5	50	12	24	10	40	38	30	0.5	2.5	30	42
502251-C8	RMMC-ND-A1-L-FT-C8	7	10	5.5	4.5	50	12	24	10	40	38	30	0.5	2.5	30	42

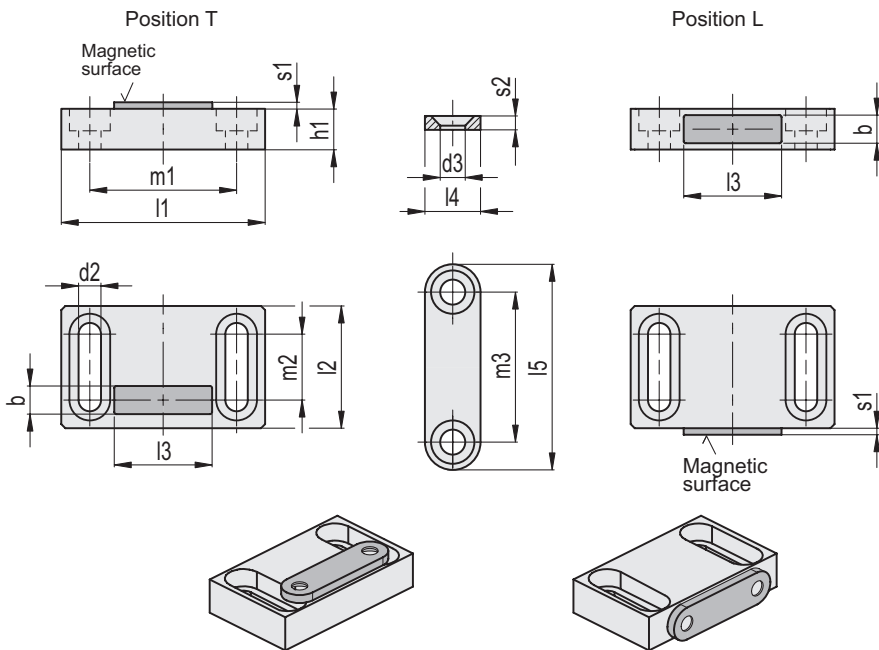

METRIC

RMMC-A2-FT

Code	Description	b	h1	d2	d3	l1	l2	l3	l4	l5	m1	m2	m3	s1	s2	Nominal adhesive forces* [N]	⚖️
502258-C9	RMMC-ND-A2-T-FT-C9	7	10	5.5	4.5	50	30	24	10	40	38	18	30	0.5	2.5	30	62
502265-C9	RMMC-ND-A2-L-FT-C9	7	10	5.5	4.5	50	30	24	10	40	38	18	30	0.5	2.5	30	62
502271-C8	RMMC-ND-A2-T-FT-C8	7	10	5.5	4.5	50	30	24	10	40	38	18	30	0.5	2.5	30	62
502278-C8	RMMC-ND-A2-L-FT-C8	7	10	5.5	4.5	50	30	24	10	40	38	18	30	0.5	2.5	30	62

* The values of the nominal adhesive forces are approximate and refer to magnetic properties observed on laboratory samples.

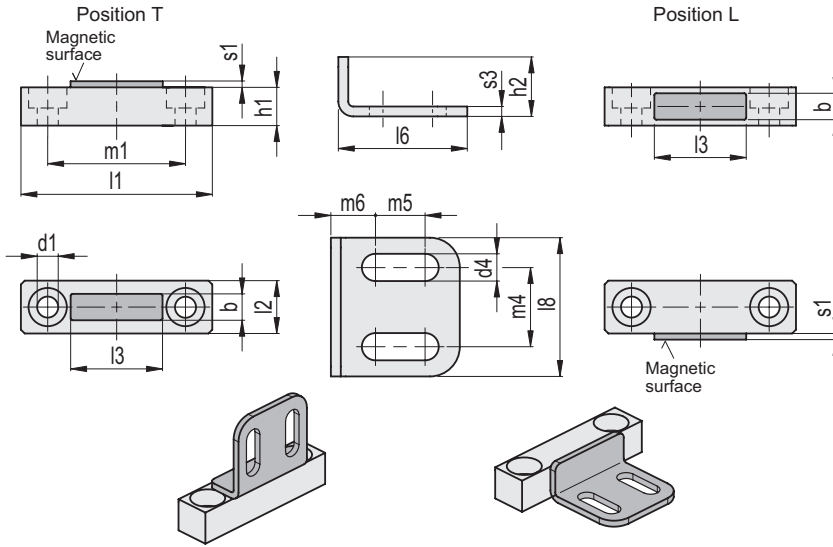

METRIC

RMMC-A1-SL

Code	Description	b	h1	h2	d1	d4	l1	l2	l3	l6	l8	m1	m4	m5	m6	s1	s3	Nominal adhesive forces* [N]	Δ
502232-C9	RMMC-ND-A1-T-SL-10-C9	7	10	12	5.5	5.5	50	12	24	26	28	38	16	10	9	0.5	2	30	48
502233-C9	RMMC-ND-A1-T-SL-14-C9	7	10	12	5.5	5.5	50	12	24	38	28	38	16	14	15	0.5	2	30	52
502239-C9	RMMC-ND-A1-L-SL-10-C9	7	10	12	5.5	5.5	50	12	24	26	28	38	16	10	9	0.5	2	30	48
502240-C9	RMMC-ND-A1-L-SL-14-C9	7	10	12	5.5	5.5	50	12	24	38	28	38	16	14	15	0.5	2	30	52
502246-C8	RMMC-ND-A1-T-SL-10-C8	7	10	12	5.5	5.5	50	12	24	26	28	38	16	10	9	0.5	2	30	48
502247-C8	RMMC-ND-A1-T-SL-14-C8	7	10	12	5.5	5.5	50	12	24	38	28	38	16	14	15	0.5	2	30	52
502252-C8	RMMC-ND-A1-L-SL-10-C8	7	10	12	5.5	5.5	50	12	24	26	28	38	16	10	9	0.5	2	30	48
502253-C8	RMMC-ND-A1-L-SL-14-C8	7	10	12	5.5	5.5	50	12	24	38	28	38	16	14	15	0.5	2	30	52

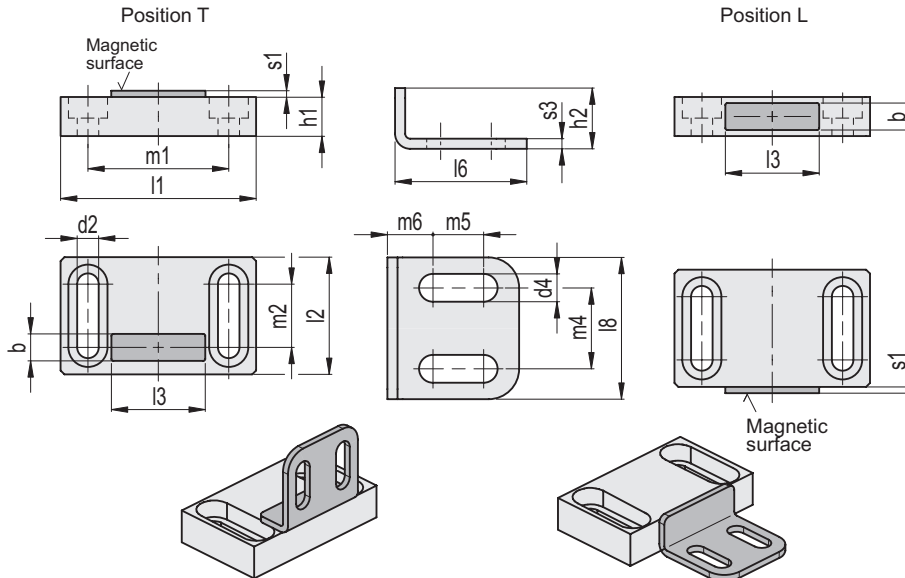

METRIC

RMMC-A2-SL

Code	Description	b	h1	h2	d2	d4	l1	l2	l3	l6	l8	m1	m2	m4	m5	m6	s1	s3	Nominal adhesive forces* [N]	Δ
502259-C9	RMMC-ND-A2-T-SL-10-C9	7	10	12	5.5	5.5	50	30	24	26	28	38	18	16	10	9	0.5	2	30	68
502260-C9	RMMC-ND-A2-T-SL-14-C9	7	10	12	5.5	5.5	50	30	24	38	28	38	18	16	14	15	0.5	2	30	72
502266-C9	RMMC-ND-A2-L-SL-10-C9	7	10	12	5.5	5.5	50	30	24	26	28	38	18	16	10	9	0.5	2	30	68
502267-C9	RMMC-ND-A2-L-SL-14-C9	7	10	12	5.5	5.5	50	30	24	38	28	38	18	16	14	15	0.5	2	30	72
502272-C8	RMMC-ND-A2-T-SL-10-C8	7	10	12	5.5	5.5	50	30	24	26	28	38	18	16	10	9	0.5	2	30	68
502273-C8	RMMC-ND-A2-T-SL-14-C8	7	10	12	5.5	5.5	50	30	24	38	28	38	18	16	14	15	0.5	2	30	72
502279-C8	RMMC-ND-A2-L-SL-10-C8	7	10	12	5.5	5.5	50	30	24	26	28	38	18	16	10	9	0.5	2	30	68
502280-C8	RMMC-ND-A2-L-SL-14-C8	7	10	12	5.5	5.5	50	30	24	38	28	38	18	16	14	15	0.5	2	30	72

* The values of the nominal adhesive forces are approximate and refer to magnetic properties observed on laboratory samples.



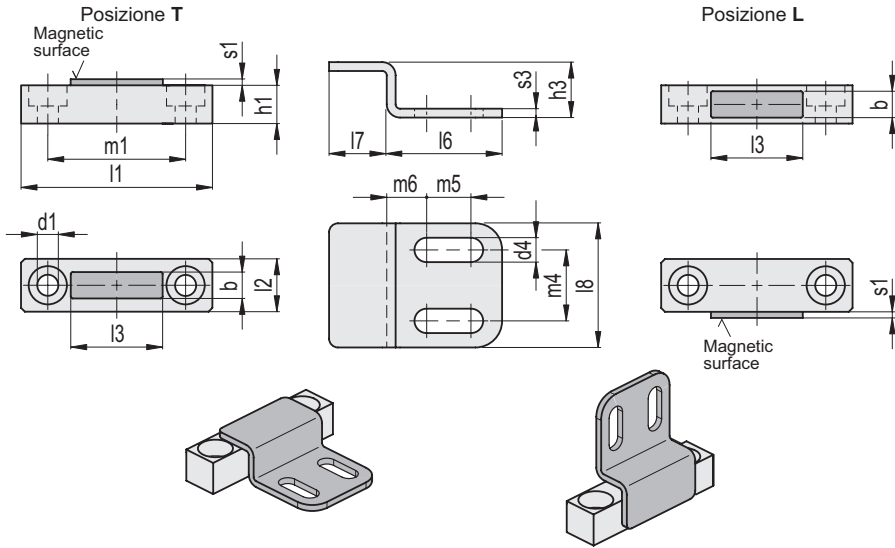

METRIC

RMMC-A1-ZSL

Code	Description	b	h1	h3	d1	d4	l1	l2	l3	l6	l7	l8	m1	m4	m5	m6	s1	s3	Nominal adhesive forces* [N]	⚖️
502234-C9	RMMC-ND-A1-T-ZSL-10-C9	7	10	12.5	5.5	5.5	50	12	24	38	13	28	38	16	10	9	0.5	2	30	54
502235-C9	RMMC-ND-A1-T-ZSL-14-C9	7	10	12.5	5.5	5.5	50	12	24	38	13	28	38	16	14	15	0.5	2	30	58
502241-C9	RMMC-ND-A1-L-ZSL-10-C9	7	10	12.5	5.5	5.5	50	12	24	26	13	28	38	16	10	9	0.5	2	30	54
502242-C9	RMMC-ND-A1-L-ZSL-14-C9	7	10	12.5	5.5	5.5	50	12	24	38	13	28	38	16	14	15	0.5	2	30	58
502248-C8	RMMC-ND-A1-T-ZSL-10-C8	7	10	12.5	5.5	5.5	50	12	24	26	13	28	38	16	10	9	0.5	2	30	54
502249-C8	RMMC-ND-A1-T-ZSL-14-C8	7	10	12.5	5.5	5.5	50	12	24	38	13	28	38	16	14	15	0.5	2	30	58
502254-C8	RMMC-ND-A1-L-ZSL-10-C8	7	10	12.5	5.5	5.5	50	12	24	26	13	28	38	16	10	9	0.5	2	30	54
502255-C8	RMMC-ND-A1-L-ZSL-14-C8	7	10	12.5	5.5	5.5	50	12	24	38	13	28	38	16	14	15	0.5	2	30	58

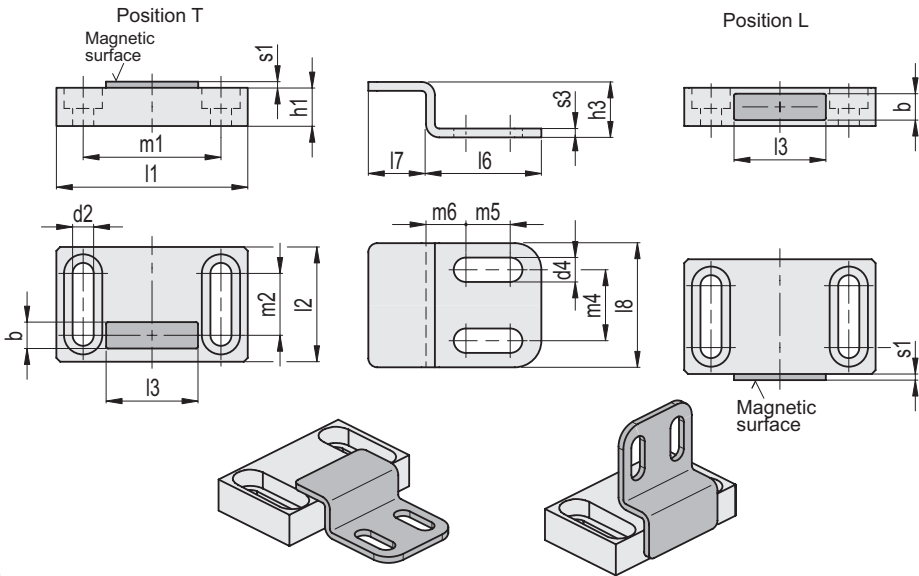

METRIC

RMMC-A2-ZSL

Code	Description	b	h1	h3	d2	d4	l1	l2	l3	l6	l7	l8	m1	m2	m4	m5	m6	s1	s3	Nominal adhesive forces* [N]	⚖️
502261-C9	RMMC-ND-A2-T-ZSL-10-C9	7	10	12.5	5.5	5.5	50	30	24	26	13	28	38	18	16	10	9	0.5	2	30	74
502262-C9	RMMC-ND-A2-T-ZSL-14-C9	7	10	12.5	5.5	5.5	50	30	24	38	13	28	38	18	16	14	15	0.5	2	30	78
502268-C9	RMMC-ND-A2-L-ZSL-10-C9	7	10	12.5	5.5	5.5	50	30	24	26	13	28	38	18	16	10	9	0.5	2	30	74
502269-C9	RMMC-ND-A2-L-ZSL-14-C9	7	10	12.5	5.5	5.5	50	30	24	38	13	28	38	18	16	14	15	0.5	2	30	78
502274-C8	RMMC-ND-A2-T-ZSL-10-C8	7	10	12.5	5.5	5.5	50	30	24	26	13	28	38	18	16	10	9	0.5	2	30	74
502275-C8	RMMC-ND-A2-T-ZSL-14-C8	7	10	12.5	5.5	5.5	50	30	24	38	13	28	38	18	16	14	15	0.5	2	30	78
502281-C8	RMMC-ND-A2-L-ZSL-10-C8	7	10	12.5	5.5	5.5	50	30	24	26	13	28	38	18	16	10	9	0.5	2	30	74
502282-C8	RMMC-ND-A2-L-ZSL-14-C8	7	10	12.5	5.5	5.5	50	30	24	38	13	28	38	18	16	14	15	0.5	2	30	78

* The values of the nominal adhesive forces are approximate and refer to magnetic properties observed on laboratory samples.