

- 1
- 2
- 3
- 4
- 5
- 6
- 7
- 8
- 9
- 10
- 11
- 12
- 13
- 14
- 15
- 16
- 17
- 18
- 19

MATERIAL

Zinc-plated steel threaded insert.

NO-SLIP COATING

Thermoplastic elastomer (TPE), hardness 80 shore A.

STANDARD EXECUTION

Magnet in neodymium iron boron (NdFeB)

D=12÷43 temperatures to 60°C, D=57÷88 temperatures up to 80°C.

- **RMH-ND-BK**: threaded pin, no-slip coating in RAL 9011 black colour.

- **RMH-ND-WT**: threaded pin, no-slip coating in RAL 9016 white colour.

Retaining magnets technical data (on page 756).

FEATURES AND APPLICATIONS

RMG flat retaining magnets are shielded magnetic systems with high performances and moderate overall dimensions. !da duplicazione!

The elastomer surface increases the friction coefficient when lateral retaining forces are present, giving a better adhesion. These magnets are preferably used for sensitive surfaces.



Conversion Table	
1 mm = 0.039 inch	
D	
mm	inch
12	0.47
18	0.70
22	0.86
31	1.21
43	1.68
57	2.22
66	2.57
88	3.43

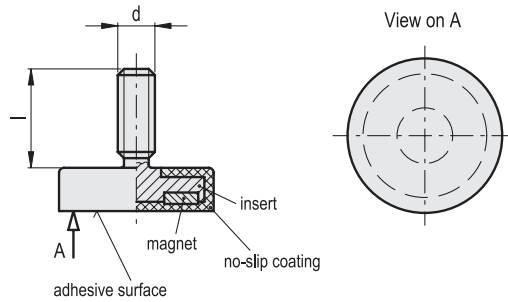

RMH-ND-BK

METRIC

Code	Description	D	d	L	l	Nominal adhesive forces* [N]	⚖
501691	RMH-ND-12-BK	12	M4	7.5	8	13	4.5
501696	RMH-ND-18-BK	18	M4	6	6	37	8
501701	RMH-ND-22-BK	22	M4	6	6.5	58	11
501706	RMH-ND-31-BK	31	M6	6	11	89	24
501711	RMH-ND-43-BK	43	M6	6	15	100	32
501716	RMH-ND-57-BK	57	M6	7.6	15	200	82
501721	RMH-ND-66-BK	66	M8	8.5	15	250	107
501731	RMH-ND-88-BK	88	M8	8.5	15	550	193

RMH-ND-WT

Code	Description	D	d	L	l	Nominal adhesive forces* [N]	⚖
501693	RMH-ND-12-WT	12	M4	7.5	8	13	4.5
501697	RMH-ND-18-WT	18	M4	6	6	37	8
501703	RMH-ND-22-WT	22	M4	6	6.5	58	11
501707	RMH-ND-31-WT	31	M6	6	11	89	24
501713	RMH-ND-43-WT	43	M6	6	15	100	32
501717	RMH-ND-57-WT	57	M6	7.6	15	200	82
501723	RMH-ND-66-WT	66	M8	8.5	15	250	107
501733	RMH-ND-88-WT	88	M8	8.5	15	550	193

Industrial magnets

* The values of the nominal adhesive forces are approximate and refer to magnetic properties observed on laboratory samples.