

LVQ.F-SST-VD | Levelling feet for ground mounting

Visually Detectable technopolymer base, stainless steel stem



METRIC



ELESA Original design

- 1
- 2
- 3
- 4
- 5
- 6
- 7
- 8
- 9
- 10
- 11
- 12
- 13
- 14
- 15
- 16
- 17
- 18

BASE

Glass-fibre reinforced polyamide based (PA) technopolymer, RAL 5005 blue colour, matte finish.

Produced from FDA compliant raw material (FDA CFR.21 and EU 10/2011).

ARTICULATED STEM

Threaded AISI 304 stainless steel with adjusting square.

STANDARD EXECUTIONS

- LVQ.F-SST-VD: without no-slip disk.
- LVQ.F-AS-SST-VD: with NBR rubber no-slip disk, hardness 70 Shore A, supplied assembled to the base.

GROUND MOUNTING

By means of two holes at 180°, supplied covered by a diaphragm (which can be easily removed by a metal tool), to avoid all unhealthy deposits of dirt and dust when the ground mounting is not required (see Fig.1).

FEATURES AND APPLICATIONS

The RAL 5005 blue colour is easily visible in case of accidental food contamination.

The special knurling under the lower lip of the base provides excellent stability and grip when using the levelling element without no-slip disk even on surfaces that are not perfectly flat.

The particular assembling system of the no-slip disk to the base assures a perfect anchoring, preventing separation even in case of impact during transport or of adhesion (sticking) to the floor (see No-slip disks on page 835).

ORDER INFORMATION

The levelling feet are supplied unassembled to make carriage and storage easier. The components (base and stem) are supplied in separate packing: less volume taken and better protection from scratches and dirt.

To order bases and stems separately, see:

- table of possible combinations Bases/Stems (see page 839)
- the codes of the Bases (see page 836)
- the codes of the Stems (see page 840).

ACCESSORIES ON REQUEST

AISI 304 stainless steel nut (see Nuts NT. on page 835).

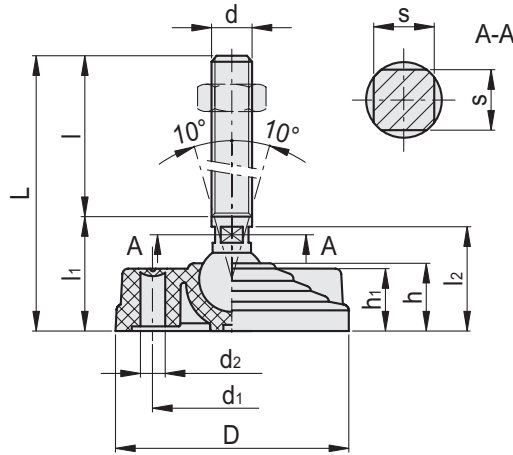

Conversion Table	
1 mm = 0.039 inch	
D	
mm	inch
80	3.12
100	3.90

LVQ.F-SST-VD

INOX STAINLESS STEEL **METRIC**

Code	Description	D	d	d1	L	l	l1	l2	d2	h	h1	s	Articulation Ø	Max. limit static load* [N]	⚖️
185381	LVQ.F-80-14-SST-M16x68-VD	80	M16	54	102	68	34	32.5	8.5	24	23	12	14	16000	151
185383	LVQ.F-80-14-SST-M16x108-VD	80	M16	54	142	108	34	32.5	8.5	24	23	12	14	16000	215
185385	LVQ.F-80-14-SST-M16x148-VD	80	M16	54	182	148	34	32.5	8.5	24	23	12	14	16000	279
185387	LVQ.F-80-14-SST-M16x168-VD	80	M16	54	202	168	34	32.5	8.5	24	23	12	14	16000	311
185391	LVQ.F-80-14-SST-M20x110-VD	80	M20	54	149	110	39	36.5	8.5	24	23	15	14	16000	315
185393	LVQ.F-80-14-SST-M20x150-VD	80	M20	54	189	150	39	36.5	8.5	24	23	15	14	16000	415
185395	LVQ.F-80-14-SST-M20x170-VD	80	M20	54	209	170	39	36.5	8.5	24	23	15	14	16000	465
185397	LVQ.F-80-14-SST-M20x210-VD	80	M20	54	249	210	39	36.5	8.5	24	23	15	14	16000	564
185398	LVQ.F-80-14-SST-M24x110-VD	80	M24	54	149	110	39	36.5	8.5	24	23	18	14	16000	422
185399	LVQ.F-80-14-SST-M24x170-VD	80	M24	54	209	170	39	36.5	8.5	24	23	18	14	16000	637
185400	LVQ.F-80-14-SST-M24x210-VD	80	M24	54	249	210	39	36.5	8.5	24	23	18	14	16000	781
185481	LVQ.F-100-14-SST-M16x68-VD	100	M16	70	102	68	34	32.5	12.5	24	23	12	14	16000	181
185483	LVQ.F-100-14-SST-M16x108-VD	100	M16	70	142	108	34	32.5	12.5	24	23	12	14	16000	245
185485	LVQ.F-100-14-SST-M16x148-VD	100	M16	70	182	148	34	32.5	12.5	24	23	12	14	16000	309
185487	LVQ.F-100-14-SST-M16x168-VD	100	M16	70	202	168	34	32.5	12.5	24	23	12	14	16000	341
185491	LVQ.F-100-14-SST-M20x110-VD	100	M20	70	149	110	39	36.5	12.5	24	23	15	14	16000	345
185493	LVQ.F-100-14-SST-M20x150-VD	100	M20	70	189	150	39	36.5	12.5	24	23	15	14	16000	445
185495	LVQ.F-100-14-SST-M20x170-VD	100	M20	70	209	170	39	36.5	12.5	24	23	15	14	16000	495
185497	LVQ.F-100-14-SST-M20x210-VD	100	M20	70	249	210	39	36.5	12.5	24	23	15	14	16000	594
185498	LVQ.F-100-14-SST-M24x110-VD	100	M24	70	149	110	39	36.5	12.5	24	23	18	14	16000	452
185499	LVQ.F-100-14-SST-M24x170-VD	100	M24	70	209	170	39	36.5	12.5	24	23	18	14	16000	667
185500	LVQ.F-100-14-SST-M24x210-VD	100	M24	70	249	210	39	36.5	12.5	24	23	18	14	16000	811

* The max static load is the value above which the load applied to the element may cause some plastic material breakage, in particular conditions of use. Obviously, a factor that takes into consideration the importance and the safety level of the specific application must be applied to this value.

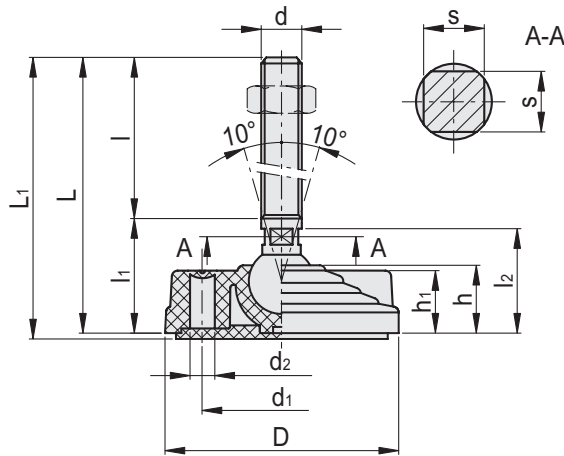
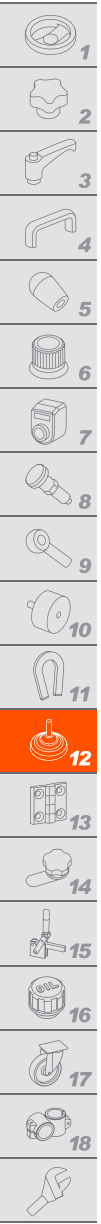

Conversion Table	
1 mm = 0.039 inch	
D	
mm	inch
80	3.12
100	3.90

LVQ.F-AS-SST-VD



Code	Description	D	d	d1	L	L1	l	l1	l2	d2	h	h1	s	Articulation Ø	Max. limit static load* [N]	⚖️
186381	LVQ.F-80-14-AS-SST-M16x68-VD	80	M16	54	102	105	68	34	32.5	8.5	24	23	12	14	16000	177
186383	LVQ.F-80-14-AS-SST-M16x108-VD	80	M16	54	142	145	108	34	32.5	8.5	24	23	12	14	16000	241
186385	LVQ.F-80-14-AS-SST-M16x148-VD	80	M16	54	182	185	148	34	32.5	8.5	24	23	12	14	16000	305
186387	LVQ.F-80-14-AS-SST-M16x168-VD	80	M16	54	202	205	168	34	32.5	8.5	24	23	12	14	16000	337
186391	LVQ.F-80-14-AS-SST-M20x110-VD	80	M20	54	149	152	110	39	36.5	8.5	24	23	15	14	16000	341
186393	LVQ.F-80-14-AS-SST-M20x150-VD	80	M20	54	189	192	150	39	36.5	8.5	24	23	15	14	16000	441
186395	LVQ.F-80-14-AS-SST-M20x170-VD	80	M20	54	209	212	170	39	36.5	8.5	24	23	15	14	16000	491
186397	LVQ.F-80-14-AS-SST-M20x210-VD	80	M20	54	249	252	210	39	36.5	8.5	24	23	15	14	16000	590
186398	LVQ.F-80-14-AS-SST-M24x110-VD	80	M24	54	149	152	110	39	36.5	8.5	24	23	18	14	16000	448
186399	LVQ.F-80-14-AS-SST-M24x170-VD	80	M24	54	209	212	170	39	36.5	8.5	24	23	18	14	16000	663
186400	LVQ.F-80-14-AS-SST-M24x210-VD	80	M24	54	249	252	210	39	36.5	8.5	24	23	18	14	16000	807
186481	LVQ.F-100-14-AS-SST-M16x68-VD	100	M16	70	102	105	68	34	32.5	12.5	24	23	12	14	16000	235
186483	LVQ.F-100-14-AS-SST-M16x108-VD	100	M16	70	142	145	108	34	32.5	12.5	24	23	12	14	16000	299
186485	LVQ.F-100-14-AS-SST-M16x148-VD	100	M16	70	182	185	148	34	32.5	12.5	24	23	12	14	16000	363
186487	LVQ.F-100-14-AS-SST-M16x168-VD	100	M16	70	202	205	168	34	32.5	12.5	24	23	12	14	16000	395
186491	LVQ.F-100-14-AS-SST-M20x110-VD	100	M20	70	149	152	110	39	36.5	12.5	24	23	15	14	16000	399
186493	LVQ.F-100-14-AS-SST-M20x150-VD	100	M20	70	189	192	150	39	36.5	12.5	24	23	15	14	16000	499
186495	LVQ.F-100-14-AS-SST-M20x170-VD	100	M20	70	209	212	170	39	36.5	12.5	24	23	15	14	16000	549
186497	LVQ.F-100-14-AS-SST-M20x210-VD	100	M20	70	249	252	210	39	36.5	12.5	24	23	15	14	16000	648
186498	LVQ.F-100-14-AS-SST-M24x110-VD	100	M24	70	149	152	110	39	36.5	12.5	24	23	18	14	16000	506
186499	LVQ.F-100-14-AS-SST-M24x170-VD	100	M24	70	209	212	170	39	36.5	12.5	24	23	18	14	16000	721
186500	LVQ.F-100-14-AS-SST-M24x210-VD	100	M24	70	249	252	210	39	36.5	12.5	24	23	18	14	16000	865

* The max static load is the value above which the load applied to the element may cause some plastic material breakage, in particular conditions of use. Obviously, a factor that takes into consideration the importance and the safety level of the specific application must be applied to this value.

Levelling feet and supports