

- 1
- 2
- 3
- 4
- 5
- 6
- 7
- 8
- 9
- 10
- 11
- 12
- 13
- 14
- 15
- 16
- 17
- 18
- 19

BASE

Glass-fibre reinforced polyamide based (PA) special conductive technopolymer, black colour, matte finish.
 Surface resistivity = $10^3 \Omega$ (ASTM D257 measuring method).
 Volume resistivity = $10^3 \Omega\text{cm}$ (ASTM D257 measuring method).

ARTICULATED STEM

Threaded zinc-plated steel with regulation hexagon.

STANDARD EXECUTIONS

- **LV.F-ESD-C**: without no-slip disk.
 - **LV.F-AS-ESD-C**: with NBR rubber no-slip disk, hardness 70 Shore A, supplied assembled to the base.
- Surface resistivity = $10^3 \Omega$ (ASTM D991 measuring method).
 Volume resistivity = $10^3 \Omega\text{cm}$ (ASTM D991 measuring method).

GROUND MOUNTING

By means of two holes at 180°, supplied covered by a diaphragm (which can be easily removed by a metal tool), to avoid all unhealthy deposits of dirt and dust when the ground mounting is not required (see Fig.1).

Features and applications

The special conductive technopolymer (ESD-C Electrostatic Discharge Conductive) prevents the accumulation of electrostatic charge.
 The particular assembling system of the no-slip disk to the base assures a perfect anchoring, preventing separation even in case of impact during transport or of adhesion (sticking) to the floor (see No-slip disks on page 835).
 The special knurling under the lower lip of the base provides excellent stability and grip when using the levelling element without no-slip disk even on surfaces that are not perfectly flat.
 The bases are suitable for "ESD PROTECTED AREA" (EPA) where components, which are susceptible to electrostatic discharges, are handled.
 The (ESD-C) indelibly printed mark on the surface of the levelling feet bases identifies the particular conductive features of the material according to EN 100015/1 and IEC 61340-5-1.

ORDER INFORMATION

The levelling elements are supplied unassembled to make carriage and storage easier. The components (base and stem) are supplied in separate packing: less volume taken and better protection from scratches and dirt.
 To order bases and stems separately, see:
 - table of possible combinations Bases/Stems (see page 839)
 - the codes of the Bases (see page 836)
 - the codes of the Stems (see page 985).

ACCESSORIES ON REQUEST

Zinc-plated steel nut (see Nuts NT. on page 835).



ELESA Original design

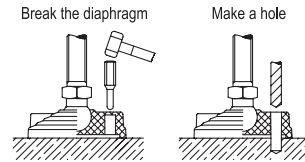
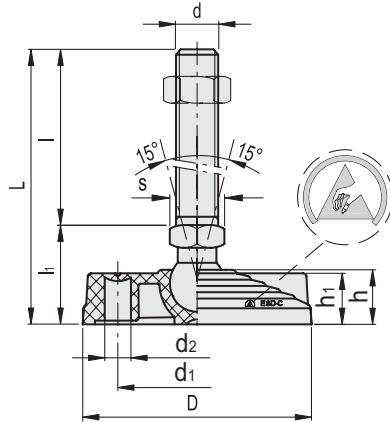

Fig.1



INCH

LV.F-ESD-C

Code	Description	D	d2A	L	l	l1	d1	d2	h	h1	s	Articulation ∅	Max. limit static load* [lbf]	⚖️
90312451-ESD	LV.F-100-14-3/8-16X2-ESD-C	3.94	3/8-16	3.30	2	1.30	2.76	0.49	0.94	0.91	9/16	0.55	4046.56	0.31
90312453-ESD	LV.F-100-14-3/8-16X4-ESD-C	3.94	3/8-16	5.30	4	1.30	2.76	0.49	0.94	0.91	9/16	0.55	4046.56	0.35
90312455-ESD	LV.F-100-14-3/8-16X6-ESD-C	3.94	3/8-16	7.30	6	1.30	2.76	0.49	0.94	0.91	9/16	0.55	4046.56	0.37
90312471-ESD	LV.F-100-14-1/2-13X2-ESD-C	3.94	1/2-13	3.30	2	1.30	2.76	0.49	0.94	0.91	9/16	0.55	4046.56	0.34
90312473-ESD	LV.F-100-14-1/2-13X4-ESD-C	3.94	1/2-13	5.30	4	1.30	2.76	0.49	0.94	0.91	9/16	0.55	4046.56	0.43
90312475-ESD	LV.F-100-14-1/2-13X6-ESD-C	3.94	1/2-13	7.30	6	1.30	2.76	0.49	0.94	0.91	9/16	0.55	4046.56	0.41
90312481-ESD	LV.F-100-14-5/8-11X4-ESD-C	3.94	5/8-11	5.30	4	1.30	2.76	0.49	0.94	0.91	5/8	0.55	4046.56	0.53
90312483-ESD	LV.F-100-14-5/8-11X6-ESD-C	3.94	5/8-11	7.30	6	1.30	2.76	0.49	0.94	0.91	5/8	0.55	4046.56	0.69
90312485-ESD	LV.F-100-14-5/8-11X8-ESD-C	3.94	5/8-11	9.30	8	1.30	2.76	0.49	0.94	0.91	5/8	0.55	4046.56	0.74

* The max static load is the value above which the load applied to the element may cause some plastic material breakage, in particular conditions of use. Obviously, a factor that takes into consideration the importance and the safety level of the specific application must be applied to this value.

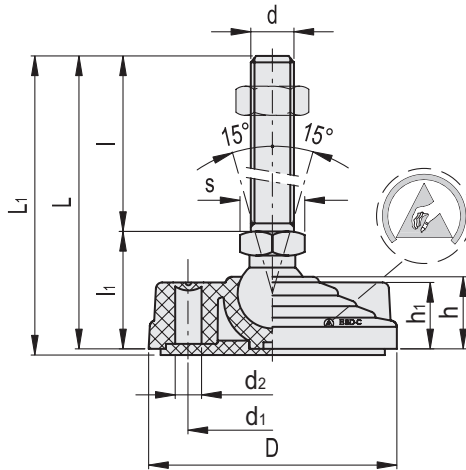

INCH

LV.F-AS-ESD-C

Code	Description	D	d2A	L	L1	l	l1	d1	d2	h	h1	s	Articulation ∅	Max. limit static load* [lbf]	⚖️
90315451-ESD	LV.F-100-14-AS-3/8-16X2-ESD-C	3.94	3/8-16	3.30	3.42	2	1.30	2.76	0.49	0.94	0.91	9/16	0.55	4046.56	0.40
90315453-ESD	LV.F-100-14-AS-3/8-16X4-ESD-C	3.94	3/8-16	5.30	5.42	4	1.30	2.76	0.49	0.94	0.91	9/16	0.55	4046.56	0.45
90315455-ESD	LV.F-100-14-AS-3/8-16X6-ESD-C	3.94	3/8-16	7.30	7.42	6	1.30	2.76	0.49	0.94	0.91	9/16	0.55	4046.56	0.46
90315471-ESD	LV.F-100-14-AS-1/2-13X2-ESD-C	3.94	1/2-13	3.30	3.42	2	1.30	2.76	0.49	0.94	0.91	9/16	0.55	4046.56	0.44
90315473-ESD	LV.F-100-14-AS-1/2-13X4-ESD-C	3.94	1/2-13	5.30	5.42	4	1.30	2.76	0.49	0.94	0.91	9/16	0.55	4046.56	0.52
90315475-ESD	LV.F-100-14-AS-1/2-13X6-ESD-C	3.94	1/2-13	7.30	7.42	6	1.30	2.76	0.49	0.94	0.91	9/16	0.55	4046.56	0.50
90315481-ESD	LV.F-100-14-AS-5/8-11X4-ESD-C	3.94	5/8-11	5.30	5.42	4	1.30	2.76	0.49	0.94	0.91	5/8	0.55	4046.56	0.63
90315483-ESD	LV.F-100-14-AS-5/8-11X6-ESD-C	3.94	5/8-11	7.30	7.42	6	1.30	2.76	0.49	0.94	0.91	5/8	0.55	4046.56	0.78
90315485-ESD	LV.F-100-14-AS-5/8-11X8-ESD-C	3.94	5/8-11	9.30	9.42	8	1.30	2.76	0.49	0.94	0.91	5/8	0.55	4046.56	0.84

* The max static load is the value above which the load applied to the element may cause some plastic material breakage, in particular conditions of use. Obviously, a factor that takes into consideration the importance and the safety level of the specific application must be applied to this value.