

- 1
- 2
- 3
- 4
- 5
- 6
- 7
- 8
- 9
- 10
- 11
- 12
- 13
- 14
- 15
- 16
- 17
- 18

**BASE**

Glass-fibre reinforced polyamide based (PA) technopolymer, RAL 5005 blue colour, matte finish.

Produced from FDA compliant raw material (FDA CFR.21 and EU 10/2011).

**ARTICULATED STEM**

Threaded AISI 304 stainless steel with regulation hexagon.

**STANDARD EXECUTIONS**

- **LS.A-SST-VD**: without no-slip disk.
- **LS.A-AS-SST-VD**: with NBR rubber no-slip disk, hardness 70 Shore A, supplied assembled to the base.

**FEATURES AND APPLICATIONS**

The RAL 5005 blue colour is easily visible in case of accidental food contamination.

The particular assembling system of the no-slip disk to the base assures a perfect anchoring, preventing separation even in case of impact during transport or of adhesion (sticking) to the floor (see No-slip disks on page 835).

**ORDER INFORMATION**

The levelling feet are supplied unassembled to make carriage and storage easier. The components (base and stem) are supplied in separate packing: less volume taken and better protection from scratches and dirt.

To order bases and stems separately, see:

- table of possible combinations Bases/Stems (see page 839)
- the codes of the Bases (see page 836)
- the codes of the Stems (see page 840).

**ACCESSORIES ON REQUEST**

AISI 304 stainless steel nut (see Nuts NT. on page 835).



ELESA Original design

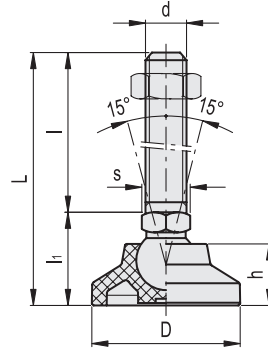

| Conversion Table<br>1 mm = 0.039 inch |      |
|---------------------------------------|------|
| D                                     |      |
| mm                                    | inch |
| 25                                    | 0.98 |
| 32                                    | 1.25 |
| 40                                    | 1.56 |
| 50                                    | 1.95 |
| 60                                    | 2.34 |

**LS.A-SST-VD**

| Code   | Description               | D  | d   | L   | l   | l1 | h  | s  | Articulation Ø | Max. limit static load* [N] | ⚖️  |
|--------|---------------------------|----|-----|-----|-----|----|----|----|----------------|-----------------------------|-----|
| 187101 | LS.A-25-14-SST-M8x43-VD   | 25 | M8  | 67  | 43  | 24 | 12 | 14 | 14             | 7000                        | 33  |
| 187103 | LS.A-25-14-SST-M8x68-VD   | 25 | M8  | 92  | 68  | 24 | 12 | 14 | 14             | 7000                        | 43  |
| 187111 | LS.A-25-14-SST-M10x43-VD  | 25 | M10 | 67  | 43  | 24 | 12 | 14 | 14             | 7000                        | 43  |
| 187113 | LS.A-25-14-SST-M10x68-VD  | 25 | M10 | 92  | 68  | 24 | 12 | 14 | 14             | 7000                        | 56  |
| 187115 | LS.A-25-14-SST-M10x98-VD  | 25 | M10 | 122 | 98  | 24 | 12 | 14 | 14             | 7000                        | 70  |
| 187121 | LS.A-25-14-SST-M12x43-VD  | 25 | M12 | 67  | 43  | 24 | 12 | 14 | 14             | 7000                        | 53  |
| 187123 | LS.A-25-14-SST-M12x68-VD  | 25 | M12 | 92  | 68  | 24 | 12 | 14 | 14             | 7000                        | 71  |
| 187125 | LS.A-25-14-SST-M12x98-VD  | 25 | M12 | 122 | 98  | 24 | 12 | 14 | 14             | 7000                        | 93  |
| 187131 | LS.A-25-14-SST-M14x68-VD  | 25 | M14 | 92  | 68  | 24 | 12 | 14 | 14             | 7000                        | 86  |
| 187133 | LS.A-25-14-SST-M14x98-VD  | 25 | M14 | 122 | 98  | 24 | 12 | 14 | 14             | 7000                        | 107 |
| 187135 | LS.A-25-14-SST-M14x148-VD | 25 | M14 | 172 | 148 | 24 | 12 | 14 | 14             | 7000                        | 190 |
| 187141 | LS.A-25-14-SST-M16x68-VD  | 25 | M16 | 92  | 68  | 24 | 12 | 16 | 14             | 7000                        | 116 |
| 187143 | LS.A-25-14-SST-M16x108-VD | 25 | M16 | 132 | 108 | 24 | 12 | 16 | 14             | 7000                        | 167 |
| 187145 | LS.A-25-14-SST-M16x148-VD | 25 | M16 | 172 | 148 | 24 | 12 | 16 | 14             | 7000                        | 220 |
| 187147 | LS.A-25-14-SST-M16x168-VD | 25 | M16 | 192 | 168 | 24 | 12 | 16 | 14             | 7000                        | 247 |
| 187201 | LS.A-32-14-SST-M8x43-VD   | 32 | M8  | 68  | 43  | 25 | 15 | 14 | 14             | 9000                        | 38  |
| 187203 | LS.A-32-14-SST-M8x68-VD   | 32 | M8  | 93  | 68  | 25 | 15 | 14 | 14             | 9000                        | 48  |
| 187211 | LS.A-32-14-SST-M10x43-VD  | 32 | M10 | 68  | 43  | 25 | 15 | 14 | 14             | 9000                        | 48  |
| 187213 | LS.A-32-14-SST-M10x68-VD  | 32 | M10 | 93  | 68  | 25 | 15 | 14 | 14             | 9000                        | 61  |
| 187215 | LS.A-32-14-SST-M10x98-VD  | 32 | M10 | 123 | 98  | 25 | 15 | 14 | 14             | 9000                        | 75  |
| 187221 | LS.A-32-14-SST-M12x43-VD  | 32 | M12 | 68  | 43  | 25 | 15 | 14 | 14             | 9000                        | 58  |
| 187223 | LS.A-32-14-SST-M12x68-VD  | 32 | M12 | 93  | 68  | 25 | 15 | 14 | 14             | 9000                        | 78  |
| 187225 | LS.A-32-14-SST-M12x98-VD  | 32 | M12 | 123 | 98  | 25 | 15 | 14 | 14             | 9000                        | 98  |

\* The max static load is the value above which the load applied to the element may cause some plastic material breakage, in particular conditions of use. Obviously, a factor that takes into consideration the importance and the safety level of the specific application must be applied to this value.

Levelling feet and supports

LS.A-SST-VD

INOX STAINLESS STEEL METRIC

| Code   | Description               | D  | d   | L   | l   | l1 | h  | s  | Articulation<br>Ø | Max. limit static load*<br>[N] | ⚖️  |
|--------|---------------------------|----|-----|-----|-----|----|----|----|-------------------|--------------------------------|-----|
| 187231 | LS.A-32-14-SST-M14x68-VD  | 32 | M14 | 93  | 68  | 25 | 15 | 14 | 14                | 9000                           | 95  |
| 187233 | LS.A-32-14-SST-M14x98-VD  | 32 | M14 | 123 | 98  | 25 | 15 | 14 | 14                | 9000                           | 116 |
| 187235 | LS.A-32-14-SST-M14x148-VD | 32 | M14 | 173 | 148 | 25 | 15 | 14 | 14                | 9000                           | 199 |
| 187241 | LS.A-32-14-SST-M16x68-VD  | 32 | M16 | 93  | 68  | 25 | 15 | 16 | 14                | 9000                           | 121 |
| 187243 | LS.A-32-14-SST-M16x108-VD | 32 | M16 | 133 | 108 | 25 | 15 | 16 | 14                | 9000                           | 175 |
| 187245 | LS.A-32-14-SST-M16x148-VD | 32 | M16 | 173 | 148 | 25 | 15 | 16 | 14                | 9000                           | 228 |
| 187247 | LS.A-32-14-SST-M16x168-VD | 32 | M16 | 193 | 168 | 25 | 15 | 16 | 14                | 9000                           | 255 |
| 187301 | LS.A-40-14-SST-M8x43-VD   | 40 | M8  | 68  | 43  | 25 | 17 | 14 | 14                | 13000                          | 42  |
| 187303 | LS.A-40-14-SST-M8x68-VD   | 40 | M8  | 93  | 68  | 25 | 17 | 14 | 14                | 13000                          | 52  |
| 187311 | LS.A-40-14-SST-M10x43-VD  | 40 | M10 | 68  | 43  | 25 | 17 | 14 | 14                | 13000                          | 52  |
| 187313 | LS.A-40-14-SST-M10x68-VD  | 40 | M10 | 93  | 68  | 25 | 17 | 14 | 14                | 13000                          | 65  |
| 187315 | LS.A-40-14-SST-M10x98-VD  | 40 | M10 | 123 | 98  | 25 | 17 | 14 | 14                | 13000                          | 79  |
| 187321 | LS.A-40-14-SST-M12x43-VD  | 40 | M12 | 68  | 43  | 25 | 17 | 14 | 14                | 13000                          | 62  |
| 187323 | LS.A-40-14-SST-M12x68-VD  | 40 | M12 | 93  | 68  | 25 | 17 | 14 | 14                | 13000                          | 80  |
| 187325 | LS.A-40-14-SST-M12x98-VD  | 40 | M12 | 123 | 98  | 25 | 17 | 14 | 14                | 13000                          | 102 |
| 187331 | LS.A-40-14-SST-M14x68-VD  | 40 | M14 | 93  | 68  | 25 | 17 | 14 | 14                | 13000                          | 95  |
| 187333 | LS.A-40-14-SST-M14x98-VD  | 40 | M14 | 123 | 98  | 25 | 17 | 14 | 14                | 13000                          | 116 |
| 187335 | LS.A-40-14-SST-M14x148-VD | 40 | M14 | 173 | 148 | 25 | 17 | 14 | 14                | 13000                          | 199 |
| 187341 | LS.A-40-14-SST-M16x68-VD  | 40 | M16 | 93  | 68  | 25 | 17 | 16 | 14                | 13000                          | 125 |
| 187343 | LS.A-40-14-SST-M16x108-VD | 40 | M16 | 133 | 108 | 25 | 17 | 16 | 14                | 13000                          | 179 |
| 187345 | LS.A-40-14-SST-M16x148-VD | 40 | M16 | 173 | 148 | 25 | 17 | 16 | 14                | 13000                          | 232 |
| 187347 | LS.A-40-14-SST-M16x168-VD | 40 | M16 | 193 | 168 | 25 | 17 | 16 | 14                | 13000                          | 259 |
| 187401 | LS.A-50-14-SST-M8x43-VD   | 50 | M8  | 70  | 43  | 27 | 19 | 14 | 14                | 13000                          | 49  |
| 187403 | LS.A-50-14-SST-M8x68-VD   | 50 | M8  | 95  | 68  | 27 | 19 | 14 | 14                | 13000                          | 59  |
| 187411 | LS.A-50-14-SST-M10x43-VD  | 50 | M10 | 70  | 43  | 27 | 19 | 14 | 14                | 13000                          | 59  |
| 187413 | LS.A-50-14-SST-M10x68-VD  | 50 | M10 | 95  | 68  | 27 | 19 | 14 | 14                | 13000                          | 72  |
| 187415 | LS.A-50-14-SST-M10x98-VD  | 50 | M10 | 125 | 98  | 27 | 19 | 14 | 14                | 13000                          | 86  |
| 187421 | LS.A-50-14-SST-M12x43-VD  | 50 | M12 | 70  | 43  | 27 | 19 | 14 | 14                | 13000                          | 69  |
| 187423 | LS.A-50-14-SST-M12x68-VD  | 50 | M12 | 95  | 68  | 27 | 19 | 14 | 14                | 13000                          | 87  |
| 187425 | LS.A-50-14-SST-M12x98-VD  | 50 | M12 | 125 | 98  | 27 | 19 | 14 | 14                | 13000                          | 109 |
| 187431 | LS.A-50-14-SST-M14x68-VD  | 50 | M14 | 95  | 68  | 27 | 19 | 14 | 14                | 13000                          | 102 |
| 187433 | LS.A-50-14-SST-M14x98-VD  | 50 | M14 | 125 | 98  | 27 | 19 | 14 | 14                | 13000                          | 123 |
| 187435 | LS.A-50-14-SST-M14x148-VD | 50 | M14 | 175 | 148 | 27 | 19 | 14 | 14                | 13000                          | 206 |
| 187441 | LS.A-50-14-SST-M16x68-VD  | 50 | M16 | 95  | 68  | 27 | 19 | 16 | 14                | 13000                          | 132 |
| 187443 | LS.A-50-14-SST-M16x108-VD | 50 | M16 | 135 | 108 | 27 | 19 | 16 | 14                | 13000                          | 185 |
| 187445 | LS.A-50-14-SST-M16x148-VD | 50 | M16 | 175 | 148 | 27 | 19 | 16 | 14                | 13000                          | 239 |
| 187447 | LS.A-50-14-SST-M16x168-VD | 50 | M16 | 195 | 168 | 27 | 19 | 16 | 14                | 13000                          | 266 |
| 187501 | LS.A-60-14-SST-M8x43-VD   | 60 | M8  | 76  | 43  | 33 | 24 | 14 | 14                | 14000                          | 64  |
| 187503 | LS.A-60-14-SST-M8x68-VD   | 60 | M8  | 101 | 68  | 33 | 24 | 14 | 14                | 14000                          | 76  |
| 187511 | LS.A-60-14-SST-M10x43-VD  | 60 | M10 | 76  | 43  | 33 | 24 | 14 | 14                | 14000                          | 73  |
| 187513 | LS.A-60-14-SST-M10x68-VD  | 60 | M10 | 101 | 68  | 33 | 24 | 14 | 14                | 14000                          | 86  |
| 187515 | LS.A-60-14-SST-M10x98-VD  | 60 | M10 | 131 | 98  | 33 | 24 | 14 | 14                | 14000                          | 100 |
| 187521 | LS.A-60-14-SST-M12x43-VD  | 60 | M12 | 76  | 43  | 33 | 24 | 14 | 14                | 14000                          | 83  |
| 187523 | LS.A-60-14-SST-M12x68-VD  | 60 | M12 | 101 | 68  | 33 | 24 | 14 | 14                | 14000                          | 101 |
| 187525 | LS.A-60-14-SST-M12x98-VD  | 60 | M12 | 131 | 98  | 33 | 24 | 14 | 14                | 14000                          | 123 |
| 187531 | LS.A-60-14-SST-M14x68-VD  | 60 | M14 | 101 | 68  | 33 | 24 | 14 | 14                | 14000                          | 124 |
| 187533 | LS.A-60-14-SST-M14x98-VD  | 60 | M14 | 131 | 98  | 33 | 24 | 14 | 14                | 14000                          | 145 |
| 187535 | LS.A-60-14-SST-M14x148-VD | 60 | M14 | 181 | 148 | 33 | 24 | 14 | 14                | 14000                          | 228 |
| 187541 | LS.A-60-14-SST-M16x68-VD  | 60 | M16 | 101 | 68  | 33 | 24 | 16 | 14                | 14000                          | 146 |
| 187543 | LS.A-60-14-SST-M16x108-VD | 60 | M16 | 141 | 108 | 33 | 24 | 16 | 14                | 14000                          | 200 |
| 187545 | LS.A-60-14-SST-M16x148-VD | 60 | M16 | 181 | 148 | 33 | 24 | 16 | 14                | 14000                          | 253 |
| 187547 | LS.A-60-14-SST-M16x168-VD | 60 | M16 | 201 | 168 | 33 | 24 | 16 | 14                | 14000                          | 280 |
| 187551 | LS.A-60-24-SST-M16x58-VD  | 60 | M16 | 101 | 58  | 43 | 24 | 24 | 24                | 18000                          | 209 |
| 187553 | LS.A-60-24-SST-M16x98-VD  | 60 | M16 | 141 | 98  | 43 | 24 | 24 | 24                | 18000                          | 262 |
| 187555 | LS.A-60-24-SST-M16x138-VD | 60 | M16 | 181 | 138 | 43 | 24 | 24 | 24                | 18000                          | 313 |
| 187557 | LS.A-60-24-SST-M16x158-VD | 60 | M16 | 201 | 158 | 43 | 24 | 24 | 24                | 18000                          | 341 |
| 187561 | LS.A-60-24-SST-M20x98-VD  | 60 | M20 | 141 | 98  | 43 | 24 | 24 | 24                | 18000                          | 334 |
| 187563 | LS.A-60-24-SST-M20x138-VD | 60 | M20 | 181 | 138 | 43 | 24 | 24 | 24                | 18000                          | 415 |
| 187565 | LS.A-60-24-SST-M20x158-VD | 60 | M20 | 201 | 158 | 43 | 24 | 24 | 24                | 18000                          | 455 |
| 187567 | LS.A-60-24-SST-M20x198-VD | 60 | M20 | 241 | 198 | 43 | 24 | 24 | 24                | 18000                          | 541 |
| 187571 | LS.A-60-24-SST-M24x98-VD  | 60 | M24 | 141 | 98  | 43 | 24 | 24 | 24                | 18000                          | 435 |
| 187573 | LS.A-60-24-SST-M24x158-VD | 60 | M24 | 201 | 158 | 43 | 24 | 24 | 24                | 18000                          | 612 |
| 187575 | LS.A-60-24-SST-M24x198-VD | 60 | M24 | 241 | 198 | 43 | 24 | 24 | 24                | 18000                          | 734 |

\* The max static load is the value above which the load applied to the element may cause some plastic material breakage, in particular conditions of use. Obviously, a factor that takes into consideration the importance and the safety level of the specific application must be applied to this value.

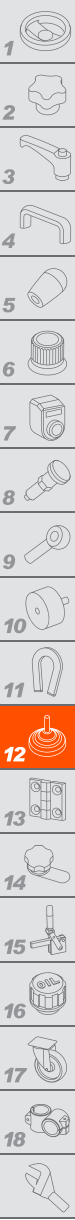

Leveling feet and supports

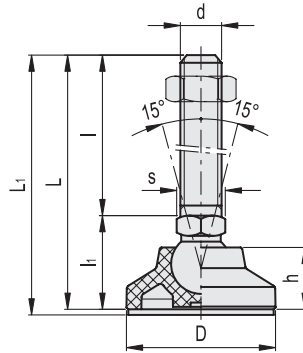
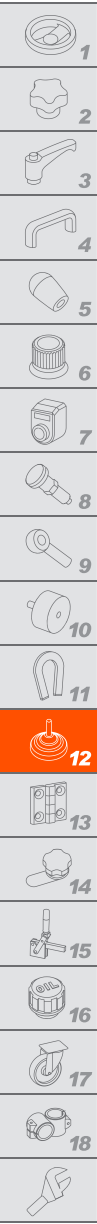

| Conversion Table<br>1 mm = 0.039 inch |      |
|---------------------------------------|------|
| D                                     |      |
| mm                                    | inch |
| 25                                    | 0.98 |
| 32                                    | 1.25 |
| 40                                    | 1.56 |
| 50                                    | 1.95 |
| 60                                    | 2.34 |

**INOX** STAINLESS STEEL **METRIC**

LS.A-AS-SST-VD

| Code   | Description                  | D  | d   | L   | L1  | l   | l1 | h  | s  | Articulation<br>∅ | Max. limit static load*<br>[N] | ⚖️  |
|--------|------------------------------|----|-----|-----|-----|-----|----|----|----|-------------------|--------------------------------|-----|
| 188101 | LS.A-25-14-AS-SST-M8x43-VD   | 25 | M8  | 67  | 70  | 43  | 24 | 12 | 14 | 14                | 7000                           | 35  |
| 188103 | LS.A-25-14-AS-SST-M8x68-VD   | 25 | M8  | 92  | 95  | 68  | 24 | 12 | 14 | 14                | 7000                           | 45  |
| 188111 | LS.A-25-14-AS-SST-M10x43-VD  | 25 | M10 | 67  | 70  | 43  | 24 | 12 | 14 | 14                | 7000                           | 45  |
| 188113 | LS.A-25-14-AS-SST-M10x68-VD  | 25 | M10 | 92  | 95  | 68  | 24 | 12 | 14 | 14                | 7000                           | 58  |
| 188115 | LS.A-25-14-AS-SST-M10x98-VD  | 25 | M10 | 122 | 125 | 98  | 24 | 12 | 14 | 14                | 7000                           | 72  |
| 188121 | LS.A-25-14-AS-SST-M12x43-VD  | 25 | M12 | 67  | 70  | 43  | 24 | 12 | 14 | 14                | 7000                           | 55  |
| 188123 | LS.A-25-14-AS-SST-M12x68-VD  | 25 | M12 | 92  | 95  | 68  | 24 | 12 | 14 | 14                | 7000                           | 73  |
| 188125 | LS.A-25-14-AS-SST-M12x98-VD  | 25 | M12 | 122 | 125 | 98  | 24 | 12 | 14 | 14                | 7000                           | 95  |
| 188131 | LS.A-25-14-AS-SST-M14x68-VD  | 25 | M14 | 92  | 95  | 68  | 24 | 12 | 14 | 14                | 7000                           | 88  |
| 188133 | LS.A-25-14-AS-SST-M14x98-VD  | 25 | M14 | 122 | 125 | 98  | 24 | 12 | 14 | 14                | 7000                           | 109 |
| 188135 | LS.A-25-14-AS-SST-M14x148-VD | 25 | M14 | 172 | 175 | 148 | 24 | 12 | 14 | 14                | 7000                           | 192 |
| 188141 | LS.A-25-14-AS-SST-M16x68-VD  | 25 | M16 | 92  | 95  | 68  | 24 | 12 | 16 | 14                | 7000                           | 118 |
| 188143 | LS.A-25-14-AS-SST-M16x108-VD | 25 | M16 | 132 | 135 | 108 | 24 | 12 | 16 | 14                | 7000                           | 169 |
| 188145 | LS.A-25-14-AS-SST-M16x148-VD | 25 | M16 | 172 | 175 | 148 | 24 | 12 | 16 | 14                | 7000                           | 222 |
| 188147 | LS.A-25-14-AS-SST-M16x168-VD | 25 | M16 | 192 | 195 | 168 | 24 | 12 | 16 | 14                | 7000                           | 249 |
| 188201 | LS.A-32-14-AS-SST-M8x43-VD   | 32 | M8  | 68  | 71  | 43  | 25 | 15 | 14 | 14                | 9000                           | 42  |
| 188203 | LS.A-32-14-AS-SST-M8x68-VD   | 32 | M8  | 93  | 96  | 68  | 25 | 15 | 14 | 14                | 9000                           | 52  |
| 188211 | LS.A-32-14-AS-SST-M10x43-VD  | 32 | M10 | 68  | 71  | 43  | 25 | 15 | 14 | 14                | 9000                           | 52  |
| 188213 | LS.A-32-14-AS-SST-M10x68-VD  | 32 | M10 | 93  | 96  | 68  | 25 | 15 | 14 | 14                | 9000                           | 65  |
| 188215 | LS.A-32-14-AS-SST-M10x98-VD  | 32 | M10 | 123 | 126 | 98  | 25 | 15 | 14 | 14                | 9000                           | 79  |
| 188221 | LS.A-32-14-AS-SST-M12x43-VD  | 32 | M12 | 68  | 71  | 43  | 25 | 15 | 14 | 14                | 9000                           | 62  |
| 188223 | LS.A-32-14-AS-SST-M12x68-VD  | 32 | M12 | 93  | 96  | 68  | 25 | 15 | 14 | 14                | 9000                           | 82  |
| 188225 | LS.A-32-14-AS-SST-M12x98-VD  | 32 | M12 | 123 | 126 | 98  | 25 | 15 | 14 | 14                | 9000                           | 102 |
| 188231 | LS.A-32-14-AS-SST-M14x68-VD  | 32 | M14 | 93  | 96  | 68  | 25 | 15 | 14 | 14                | 9000                           | 99  |
| 188233 | LS.A-32-14-AS-SST-M14x98-VD  | 32 | M14 | 123 | 126 | 98  | 25 | 15 | 14 | 14                | 9000                           | 120 |
| 188235 | LS.A-32-14-AS-SST-M14x148-VD | 32 | M14 | 173 | 176 | 148 | 25 | 15 | 14 | 14                | 9000                           | 203 |
| 188241 | LS.A-32-14-AS-SST-M16x68-VD  | 32 | M16 | 93  | 97  | 68  | 25 | 15 | 16 | 14                | 9000                           | 125 |
| 188243 | LS.A-32-14-AS-SST-M16x108-VD | 32 | M16 | 133 | 137 | 108 | 25 | 15 | 16 | 14                | 9000                           | 179 |
| 188245 | LS.A-32-14-AS-SST-M16x148-VD | 32 | M16 | 173 | 176 | 148 | 25 | 15 | 16 | 14                | 9000                           | 232 |
| 188247 | LS.A-32-14-AS-SST-M16x168-VD | 32 | M16 | 193 | 196 | 168 | 25 | 15 | 16 | 14                | 9000                           | 259 |

Levelling feet and supports

\* The max static load is the value above which the load applied to the element may cause some plastic material breakage, in particular conditions of use. Obviously, a factor that takes into consideration the importance and the safety level of the specific application must be applied to this value.

LS.A-AS-SST-VD

INOX STAINLESS STEEL METRIC

| Code   | Description                  | D  | d   | L   | L1  | l   | l1 | h  | s  | Articulation Ø | Max. limit static load* [N] | ⚖️  |
|--------|------------------------------|----|-----|-----|-----|-----|----|----|----|----------------|-----------------------------|-----|
| 188301 | LS.A-40-14-AS-SST-M8x43-VD   | 40 | M8  | 68  | 71  | 43  | 25 | 17 | 14 | 14             | 13000                       | 49  |
| 188303 | LS.A-40-14-AS-SST-M8x68-VD   | 40 | M8  | 93  | 96  | 68  | 25 | 17 | 14 | 14             | 13000                       | 59  |
| 188311 | LS.A-40-14-AS-SST-M10x43-VD  | 40 | M10 | 68  | 71  | 43  | 25 | 17 | 14 | 14             | 13000                       | 59  |
| 188313 | LS.A-40-14-AS-SST-M10x68-VD  | 40 | M10 | 93  | 96  | 68  | 25 | 17 | 14 | 14             | 13000                       | 72  |
| 188315 | LS.A-40-14-AS-SST-M10x98-VD  | 40 | M10 | 123 | 126 | 98  | 25 | 17 | 14 | 14             | 13000                       | 86  |
| 188321 | LS.A-40-14-AS-SST-M12x43-VD  | 40 | M12 | 68  | 71  | 43  | 25 | 17 | 14 | 14             | 13000                       | 69  |
| 188323 | LS.A-40-14-AS-SST-M12x68-VD  | 40 | M12 | 93  | 96  | 68  | 25 | 17 | 14 | 14             | 13000                       | 87  |
| 188325 | LS.A-40-14-AS-SST-M12x98-VD  | 40 | M12 | 123 | 126 | 98  | 25 | 17 | 14 | 14             | 13000                       | 109 |
| 188331 | LS.A-40-14-AS-SST-M14x68-VD  | 40 | M14 | 93  | 96  | 68  | 25 | 17 | 14 | 14             | 13000                       | 102 |
| 188333 | LS.A-40-14-AS-SST-M14x98-VD  | 40 | M14 | 123 | 126 | 98  | 25 | 17 | 14 | 14             | 13000                       | 123 |
| 188335 | LS.A-40-14-AS-SST-M14x148-VD | 40 | M14 | 173 | 176 | 148 | 25 | 17 | 14 | 14             | 13000                       | 206 |
| 188341 | LS.A-40-14-AS-SST-M16x68-VD  | 40 | M16 | 93  | 96  | 68  | 25 | 17 | 16 | 14             | 13000                       | 132 |
| 188343 | LS.A-40-14-AS-SST-M16x108-VD | 40 | M16 | 133 | 136 | 108 | 25 | 17 | 16 | 14             | 13000                       | 186 |
| 188345 | LS.A-40-14-AS-SST-M16x148-VD | 40 | M16 | 173 | 176 | 148 | 25 | 17 | 16 | 14             | 13000                       | 239 |
| 188347 | LS.A-40-14-AS-SST-M16x168-VD | 40 | M16 | 193 | 196 | 168 | 25 | 17 | 16 | 14             | 13000                       | 266 |
| 188401 | LS.A-50-14-AS-SST-M8x43-VD   | 50 | M8  | 70  | 73  | 43  | 27 | 19 | 14 | 14             | 13000                       | 61  |
| 188403 | LS.A-50-14-AS-SST-M8x68-VD   | 50 | M8  | 95  | 98  | 68  | 27 | 19 | 14 | 14             | 13000                       | 71  |
| 188411 | LS.A-50-14-AS-SST-M10x43-VD  | 50 | M10 | 70  | 73  | 43  | 27 | 19 | 14 | 14             | 13000                       | 71  |
| 188413 | LS.A-50-14-AS-SST-M10x68-VD  | 50 | M10 | 95  | 98  | 68  | 27 | 19 | 14 | 14             | 13000                       | 84  |
| 188415 | LS.A-50-14-AS-SST-M10x98-VD  | 50 | M10 | 125 | 128 | 98  | 27 | 19 | 14 | 14             | 13000                       | 98  |
| 188421 | LS.A-50-14-AS-SST-M12x43-VD  | 50 | M12 | 70  | 73  | 43  | 27 | 19 | 14 | 14             | 13000                       | 81  |
| 188423 | LS.A-50-14-AS-SST-M12x68-VD  | 50 | M12 | 95  | 98  | 68  | 27 | 19 | 14 | 14             | 13000                       | 99  |
| 188425 | LS.A-50-14-AS-SST-M12x98-VD  | 50 | M12 | 125 | 128 | 98  | 27 | 19 | 14 | 14             | 13000                       | 121 |
| 188431 | LS.A-50-14-AS-SST-M14x68-VD  | 50 | M14 | 95  | 98  | 68  | 27 | 19 | 14 | 14             | 13000                       | 114 |
| 188433 | LS.A-50-14-AS-SST-M14x98-VD  | 50 | M14 | 125 | 128 | 98  | 27 | 19 | 14 | 14             | 13000                       | 135 |
| 188435 | LS.A-50-14-AS-SST-M14x148-VD | 50 | M14 | 175 | 178 | 148 | 27 | 19 | 14 | 14             | 13000                       | 218 |
| 188441 | LS.A-50-14-AS-SST-M16x68-VD  | 50 | M16 | 95  | 98  | 68  | 27 | 19 | 16 | 14             | 13000                       | 144 |
| 188443 | LS.A-50-14-AS-SST-M16x108-VD | 50 | M16 | 135 | 138 | 108 | 27 | 19 | 16 | 14             | 13000                       | 197 |
| 188445 | LS.A-50-14-AS-SST-M16x148-VD | 50 | M16 | 175 | 178 | 148 | 27 | 19 | 16 | 14             | 13000                       | 251 |
| 188447 | LS.A-50-14-AS-SST-M16x168-VD | 50 | M16 | 195 | 198 | 168 | 27 | 19 | 16 | 14             | 13000                       | 278 |
| 188501 | LS.A-60-14-AS-SST-M8x43-VD   | 60 | M8  | 76  | 79  | 43  | 33 | 24 | 14 | 14             | 14000                       | 81  |
| 188503 | LS.A-60-14-AS-SST-M8x68-VD   | 60 | M8  | 101 | 104 | 68  | 33 | 24 | 14 | 14             | 14000                       | 93  |
| 188511 | LS.A-60-14-AS-SST-M10x43-VD  | 60 | M10 | 76  | 79  | 43  | 33 | 24 | 14 | 14             | 14000                       | 90  |
| 188513 | LS.A-60-14-AS-SST-M10x68-VD  | 60 | M10 | 101 | 104 | 68  | 33 | 24 | 14 | 14             | 14000                       | 103 |
| 188515 | LS.A-60-14-AS-SST-M10x98-VD  | 60 | M10 | 131 | 134 | 98  | 33 | 24 | 14 | 14             | 14000                       | 117 |
| 188521 | LS.A-60-14-AS-SST-M12x43-VD  | 60 | M12 | 76  | 79  | 43  | 33 | 24 | 14 | 14             | 14000                       | 100 |
| 188523 | LS.A-60-14-AS-SST-M12x68-VD  | 60 | M12 | 101 | 104 | 68  | 33 | 24 | 14 | 14             | 14000                       | 118 |
| 188525 | LS.A-60-14-AS-SST-M12x98-VD  | 60 | M12 | 131 | 134 | 98  | 33 | 24 | 14 | 14             | 14000                       | 140 |
| 188531 | LS.A-60-14-AS-SST-M14x68-VD  | 60 | M14 | 101 | 104 | 68  | 33 | 24 | 14 | 14             | 14000                       | 141 |
| 188533 | LS.A-60-14-AS-SST-M14x98-VD  | 60 | M14 | 131 | 134 | 98  | 33 | 24 | 14 | 14             | 14000                       | 162 |
| 188535 | LS.A-60-14-AS-SST-M14x148-VD | 60 | M14 | 181 | 184 | 148 | 33 | 24 | 14 | 14             | 14000                       | 245 |
| 188541 | LS.A-60-14-AS-SST-M16x68-VD  | 60 | M16 | 101 | 104 | 68  | 33 | 24 | 16 | 14             | 14000                       | 163 |
| 188543 | LS.A-60-14-AS-SST-M16x108-VD | 60 | M16 | 141 | 144 | 108 | 33 | 24 | 16 | 14             | 14000                       | 217 |
| 188545 | LS.A-60-14-AS-SST-M16x148-VD | 60 | M16 | 181 | 184 | 148 | 33 | 24 | 16 | 14             | 14000                       | 270 |
| 188547 | LS.A-60-14-AS-SST-M16x168-VD | 60 | M16 | 201 | 204 | 168 | 33 | 24 | 16 | 14             | 14000                       | 297 |
| 188551 | LS.A-60-24-AS-SST-M16x58-VD  | 60 | M16 | 101 | 104 | 58  | 43 | 24 | 24 | 24             | 18000                       | 226 |
| 188553 | LS.A-60-24-AS-SST-M16x98-VD  | 60 | M16 | 141 | 144 | 98  | 43 | 24 | 24 | 24             | 18000                       | 279 |
| 188555 | LS.A-60-24-AS-SST-M16x138-VD | 60 | M16 | 181 | 184 | 138 | 43 | 24 | 24 | 24             | 18000                       | 330 |
| 188557 | LS.A-60-24-AS-SST-M16x158-VD | 60 | M16 | 201 | 204 | 158 | 43 | 24 | 24 | 24             | 18000                       | 358 |
| 188561 | LS.A-60-24-AS-SST-M20x98-VD  | 60 | M20 | 141 | 144 | 98  | 43 | 24 | 24 | 24             | 18000                       | 351 |
| 188563 | LS.A-60-24-AS-SST-M20x138-VD | 60 | M20 | 181 | 184 | 138 | 43 | 24 | 24 | 24             | 18000                       | 432 |
| 188565 | LS.A-60-24-AS-SST-M20x158-VD | 60 | M20 | 201 | 204 | 158 | 43 | 24 | 24 | 24             | 18000                       | 472 |
| 188567 | LS.A-60-24-AS-SST-M20x198-VD | 60 | M20 | 241 | 244 | 198 | 43 | 24 | 24 | 24             | 18000                       | 558 |
| 188571 | LS.A-60-24-AS-SST-M24x98-VD  | 60 | M24 | 141 | 144 | 98  | 43 | 24 | 24 | 24             | 18000                       | 452 |
| 188573 | LS.A-60-24-AS-SST-M24x158-VD | 60 | M24 | 201 | 204 | 158 | 43 | 24 | 24 | 24             | 18000                       | 629 |
| 188575 | LS.A-60-24-AS-SST-M24x198-VD | 60 | M24 | 241 | 244 | 198 | 43 | 24 | 24 | 24             | 18000                       | 751 |

\* The max static load is the value above which the load applied to the element may cause some plastic material breakage, in particular conditions of use. Obviously, a factor that takes into consideration the importance and the safety level of the specific application must be applied to this value.

