



- 1
- 2
- 3
- 4
- 5
- 6
- 7
- 8
- 9
- 10
- 11
- 12
- 13
- 14
- 15
- 16
- 17
- 18

**STANDARD EXECUTIONS**

AISI 303 stainless steel base and joint with hole or threaded stem.  
 AISI 304 stainless steel nut.  
 - **LM-SST (d)**: with threaded blind bore.  
 - **LM-SST (d - l)**: with threaded stem.

**FEATURES**

The resistance of the levelling element to a static load is obviously limited by the load capacity of the stem.  
 The static load values in the table below refer to the resistance to a load applied on the axis of the levelling foot.  
 Under common working conditions, side or angular loading increases the stress on the stem and reduces its load capacity.  
 To increase the applicable load you can use the ball joint with threaded hole by inserting a steel threaded bar of higher resistance class. We recommend to insert a pressure pad between the end of the bar and the bottom of the threaded hole to reduce loading on the threading.

**SPECIAL EXECUTIONS ON REQUEST**

Executions with antistatic no-slip coating.



LM-SST (d)

LM-SST (d - l)

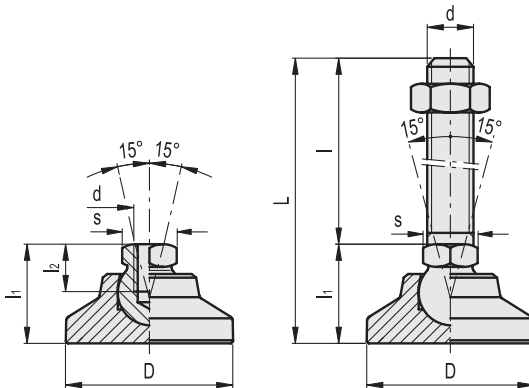

Conversion Table	
1 mm = 0.039 inch	
D	
mm	inch
25	0.98
32	1.25
40	1.56
50	1.95
60	2.34

**LM-SST (d)**

Code	Description	D	d	l1	l2	s	Max. limit static load [N]	⚖️
402020	LM.25-SST M6	25	M6	19	9	12	4000	26
402021	LM.25-SST M8	25	M8	19	9	12	7000	30
402030	LM.32-SST M8	32	M8	23	9	12	7000	62
402031	LM.32-SST M10	32	M10	23	10.5	15	11000	64
402040	LM.40-SST M10	40	M10	26	10.5	15	11000	106
402041	LM.40-SST M12	40	M12	26	11.5	17	16000	108
402050	LM.50-SST M10	50	M10	28	10.5	15	11000	173
402051	LM.50-SST M12	50	M12	28	11.5	17	16000	175
402060	LM.60-SST M12	60	M12	36	11.5	17	16000	315
402061	LM.60-SST M16	60	M16	36	16	24	30000	320



**LM-SST (d - l)**



Code	Description	D	d	L	l	l1	s	Max. limit static load [N]	⚖️
402511	LM.25-SST M6x40	25	M6	59	40	19	12	4000	39
402512	LM.25-SST M6x50	25	M6	69	50	19	12	4000	41
402513	LM.25-SST M6x63	25	M6	82	63	19	12	4000	45
402523	LM.25-SST M8x40	25	M8	59	40	19	12	7000	57
402524	LM.25-SST M8x50	25	M8	69	50	19	12	7000	55
402526	LM.25-SST M8x63	25	M8	82	63	19	12	7000	67
402516	LM.25-SST M10x50	25	M10	69	50	19	12	11000	54
402517	LM.25-SST M10x63	25	M10	82	63	19	12	11000	64
402518	LM.25-SST M10x80	25	M10	99	80	19	12	11000	76
402530	LM.32-SST M8x40	32	M8	63	40	23	12	7000	52
402531	LM.32-SST M8x50	32	M8	73	50	23	12	7000	57
402532	LM.32-SST M8x63	32	M8	86	63	23	12	7000	67
402533	LM.32-SST M10x50	32	M10	73	50	23	15	11000	113
402534	LM.32-SST M10x63	32	M10	86	63	23	15	11000	126
402536	LM.32-SST M10x80	32	M10	103	80	23	15	11000	129
402527	LM.32-SST M12x63	32	M12	86	63	23	15	16000	166
402528	LM.32-SST M12x80	32	M12	103	80	23	15	16000	183
402529	LM.32-SST M12x100	32	M12	123	100	23	15	16000	201
402537	LM.40-SST M8x50	40	M8	76	50	26	15	7000	142
402538	LM.40-SST M8x63	40	M8	89	63	26	15	7000	150
402539	LM.40-SST M8x80	40	M8	106	80	26	15	7000	158
402540	LM.40-SST M10x50	40	M10	76	50	26	15	11000	157
402541	LM.40-SST M10x63	40	M10	89	63	26	15	11000	165
402542	LM.40-SST M10x80	40	M10	106	80	26	15	11000	172
402543	LM.40-SST M12x63	40	M12	89	63	26	17	16000	185
402544	LM.40-SST M12x80	40	M12	106	80	26	17	16000	185
402546	LM.40-SST M12x100	40	M12	126	100	26	17	16000	211
402547	LM.50-SST M8x50	50	M8	78	50	28	15	7000	172
402548	LM.50-SST M8x63	50	M8	91	63	28	15	7000	180
402549	LM.50-SST M8x80	50	M8	108	80	28	15	7000	187
402550	LM.50-SST M10x50	50	M10	78	50	28	15	11000	207
402551	LM.50-SST M10x63	50	M10	91	63	28	15	11000	215
402552	LM.50-SST M10x80	50	M10	108	80	28	15	11000	222
402553	LM.50-SST M12x63	50	M12	91	63	28	17	16000	258
402554	LM.50-SST M12x80	50	M12	108	80	28	17	16000	260
402556	LM.50-SST M12x100	50	M12	128	100	28	17	16000	283
402557	LM.50-SST M16x63	50	M16	91	63	28	17	30000	286
402558	LM.50-SST M16x80	50	M16	108	80	28	17	30000	298
402559	LM.50-SST M16x100	50	M16	128	100	28	17	30000	311
402567	LM.60-SST M10x50	60	M10	86	50	36	17	11000	367
402568	LM.60-SST M10x63	60	M10	99	63	36	17	11000	386
402569	LM.60-SST M10x80	60	M10	116	80	36	17	11000	405
402560	LM.60-SST M12x63	60	M12	99	63	36	17	16000	440
402561	LM.60-SST M12x80	60	M12	116	80	36	17	16000	465
402562	LM.60-SST M12x100	60	M12	136	100	36	17	16000	500
402563	LM.60-SST M16x80	60	M16	116	80	36	24	30000	510
402565	LM.60-SST M16x100	60	M16	136	100	36	24	30000	520
402566	LM.60-SST M16x125	60	M16	161	125	36	24	30000	561
402571	LM.60-SST M20x98	60	M20	134	98	36	24	45000	550
402573	LM.60-SST M20x138	60	M20	174	138	36	24	45000	580
402576	LM.60-SST M20x158	60	M20	194	158	36	24	45000	610
402581	LM.60-SST M24x98	60	M24	134	98	36	24	45000	610
402583	LM.60-SST M24x138	60	M24	174	138	36	24	45000	630
402586	LM.60-SST M24x158	60	M24	194	158	36	24	45000	650

Levelling feet and supports