



- 1
- 2
- 3
- 4
- 5
- 6
- 7
- 8
- 9
- 10
- 11
- 12
- 13
- 14
- 15
- 16
- 17
- 18

STANDARD EXECUTIONS

AISI 303 stainless steel base and joint with hole or threaded stem.
AISI 304 stainless steel nut.

- **LM-SST-TR (d)**: with threaded blind hole.
- **LM-SST-TR (d - l)**: with threaded stem.

NON-SLIP DISK

Thermoplastic elastomer (TPE).

FEATURES

The resistance of the levelling element to a static load is obviously limited by the load capacity of the stem.

The static load values in the table below refer to the resistance to a load applied on the axis of the levelling foot.

Under common working conditions, side or angular loading increases the stress on the stem and reduces its load capacity.

To increase the applicable load you can use the ball joint with threaded hole by inserting a steel threaded bar of higher resistance class. We recommend to insert a pressure pad between the end of the bar and the bottom of the threaded hole to reduce loading on the threading.



LM-SST-TR (d)

LM-SST-TR (d - l)

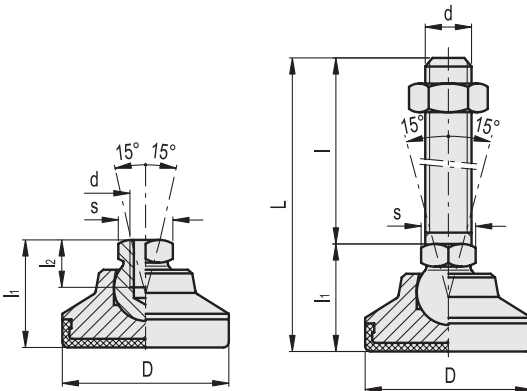

Conversion Table	
1 mm = 0.039 inch	
D	
mm	inch
25	0.98
32	1.25
40	1.56
50	1.95
60	2.34

LM-SST-TR (d)



Code	Description	D	d	l1	l2	s	Max. limit static load [N]	⚖️
402220	LM.25-SST M6-TR	25	M6	20.5	9	12	4000	40
402221	LM.25-SST M8-TR	25	M8	20.5	9	12	7000	36
402230	LM.32-SST M8-TR	32	M8	24.5	9	12	7000	85
402231	LM.32-SST M10-TR	32	M10	24.5	10.5	15	11000	77
402240	LM.40-SST M10-TR	40	M10	27.5	10.5	15	11000	120
402241	LM.40-SST M12-TR	40	M12	27.5	11.5	17	16000	113
402250	LM.50-SST M10-TR	50	M10	29.5	10.5	15	11000	185
402251	LM.50-SST M12-TR	50	M12	29.5	11.5	17	16000	165
402260	LM.60-SST M12-TR	60	M12	37.5	11.5	17	16000	335
402261	LM.60-SST M16-TR	60	M16	37.5	16	24	30000	330

LM-SST-TR (d - l)



Code	Description	D	d	L	l	l1	s	Max. limit static load [N]	⚖️
402711	LM.25-SST M6x40-TR	25	M6	60.5	40	20.5	12	4000	39
402712	LM.25-SST M6x50-TR	25	M6	70.5	50	20.5	12	4000	41
402713	LM.25-SST M6x63-TR	25	M6	83.5	63	20.5	12	4000	45
402723	LM.25-SST M8x40-TR	25	M8	60.5	40	20.5	12	7000	68
402724	LM.25-SST M8x50-TR	25	M8	70.5	50	20.5	12	7000	50
402726	LM.25-SST M8x63-TR	25	M8	83.5	63	20.5	12	7000	72
402716	LM.25-SST M10x50-TR	25	M10	70.5	50	20.5	12	11000	54
402717	LM.25-SST M10x63-TR	25	M10	83.5	63	20.5	12	11000	64
402718	LM.25-SST M10x80-TR	25	M10	100.5	80	20.5	12	11000	76
402730	LM.32-SST M8x40-TR	32	M8	64.5	40	24.5	12	7000	52
402731	LM.32-SST M8x50-TR	32	M8	74.5	50	24.5	12	7000	57
402732	LM.32-SST M8x63-TR	32	M8	87.5	63	24.5	12	7000	67
402733	LM.32-SST M10x50-TR	32	M10	74.5	50	24.5	15	11000	109
402734	LM.32-SST M10x63-TR	32	M10	87.5	63	24.5	15	11000	112
402736	LM.32-SST M10x80-TR	32	M10	104.5	80	24.5	15	11000	124
402727	LM.32-SST M12x63-TR	32	M12	87.5	63	24.5	15	16000	166
402728	LM.32-SST M12x80-TR	32	M12	104.5	80	24.5	15	16000	183
402729	LM.32-SST M12x100-TR	32	M12	124.5	100	24.5	15	16000	201
402737	LM.40-SST M8x50-TR	40	M8	77.5	50	27.5	15	7000	142
402738	LM.40-SST M8x63-TR	40	M8	90.5	63	27.5	15	7000	150
402739	LM.40-SST M8x80-TR	40	M8	107.5	80	27.5	15	7000	158
402740	LM.40-SST M10x50-TR	40	M10	77.5	50	27.5	15	11000	157
402741	LM.40-SST M10x63-TR	40	M10	90.5	63	27.5	15	11000	165
402742	LM.40-SST M10x80-TR	40	M10	107.5	80	27.5	15	11000	172
402743	LM.40-SST M12x63-TR	40	M12	90.5	63	27.5	17	16000	183
402744	LM.40-SST M12x80-TR	40	M12	107.5	80	27.5	17	16000	190
402746	LM.40-SST M12x100-TR	40	M12	127.5	100	27.5	17	16000	211
402747	LM.50-SST M8x50-TR	50	M8	79.5	50	29.5	15	7000	172
402748	LM.50-SST M8x63-TR	50	M8	92.5	63	29.5	15	7000	180
402749	LM.50-SST M8x80-TR	50	M8	109.5	80	29.5	15	7000	187
402750	LM.50-SST M10x50-TR	50	M10	79.5	50	29.5	15	11000	207
402751	LM.50-SST M10x63-TR	50	M10	92.5	63	29.5	15	11000	215
402752	LM.50-SST M10x80-TR	50	M10	109.5	80	29.5	15	11000	222
402753	LM.50-SST M12x63-TR	50	M12	92.5	63	29.5	17	16000	268
402754	LM.50-SST M12x80-TR	50	M12	109.5	80	29.5	17	16000	255
402756	LM.50-SST M12x100-TR	50	M12	129.5	100	29.5	17	16000	295
402757	LM.50-SST M16x63-TR	50	M16	92.5	63	29.5	17	30000	286
402758	LM.50-SST M16x80-TR	50	M16	109.5	80	29.5	17	30000	298
402759	LM.50-SST M16x100-TR	50	M16	129.5	100	29.5	17	30000	311
402767	LM.60-SST M10x50-TR	60	M10	87.5	50	37.5	17	11000	367
402768	LM.60-SST M10x63-TR	60	M10	100.5	63	37.5	17	11000	386
402769	LM.60-SST M10x80-TR	60	M10	117.5	80	37.5	17	11000	405
402760	LM.60-SST M12x63-TR	60	M12	100.5	63	37.5	17	16000	440
402761	LM.60-SST M12x80-TR	60	M12	117.5	80	37.5	17	16000	465
402762	LM.60-SST M12x100-TR	60	M12	137.5	100	37.5	17	16000	500
402763	LM.60-SST M16x80-TR	60	M16	117.5	80	37.5	24	30000	490
402765	LM.60-SST M16x100-TR	60	M16	137.5	100	37.5	24	30000	515
402766	LM.60-SST M16x125-TR	60	M16	162.5	125	37.5	24	30000	567
402771	LM.60-SST M20x98-TR	60	M20	135.5	98	37.5	24	45000	550
402773	LM.60-SST M20x138-TR	60	M20	175.5	138	37.5	24	45000	580
402776	LM.60-SST M20x158-TR	60	M20	195.5	158	37.5	24	45000	610
402781	LM.60-SST M24x98-TR	60	M24	135.5	98	37.5	24	30000	610
402783	LM.60-SST M24x138-TR	60	M24	175.5	138	37.5	24	30000	630
402786	LM.60-SST M24x158-TR	60	M24	195.5	158	37.5	24	30000	650

Levelling feet and supports