

- 1
- 2
- 3
- 4
- 5
- 6
- 7
- 8
- 9
- 10
- 11
- 12
- 13
- 14
- 15
- 16
- 17
- 18
- 19

**BASE**

AISI 304 stainless steel.

**SENSOR HOLDER PLATE**

AISI 304 stainless steel.

**SCREWS, NUTS AND WASHERS**

AISI 304 stainless steel.

**INDUCTIVE PROXIMITY SWITCH**

- Body: AISI 304 stainless steel, M8x1 threaded.
- Retaining nuts: AISI 304 stainless steel.
- Spring washers: AISI 304 stainless steel.

**STANDARD EXECUTIONS**

- **KSW-A-E**: for vertical series toggle clamps with folded base.
- **KSW-B-F**: for vertical series toggle clamps with straight base.
- **KSW-M-O**: for horizontal series toggle clamps with folded base.
- **KSW-N-P**: for horizontal series toggle clamps with straight base.

**FEATURES AND APPLICATIONS**

The control sensor kit consists of a folded or straight base to be fixed to the sensor holder plate using two threaded screws with nuts and washers, which are included in the supply. The slotted holes in the base allow the kit to be assembled on both sides of the clamp base and the inductive sensor (included in the supply) to be positioned according to the needs of the application, allowing the presence or proximity of metal objects to be detected without the need for physical contact, due to the change in the electromagnetic field that is generated and consequently detected by the sensor: This change is then converted into an electrical impulse, which is sent remotely to indicate that the clamp has been closed or opened, and in the event of accidental movement or incorrect opening caused by vibration or shock, it can trigger a blockage of the machining process.

**ACCESSORIES ON REQUEST**

Connector for sensor with 3 - 5 or 10 metre cable.



**KSW-A-E**

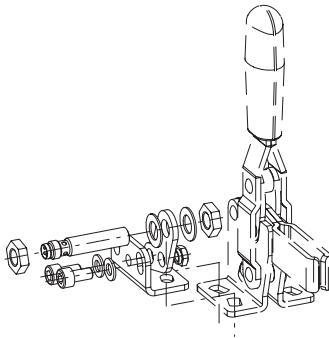

**KSW-B-F**

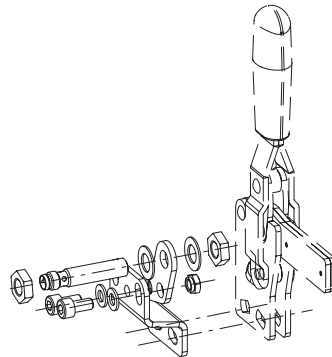

**KSW-A-E**

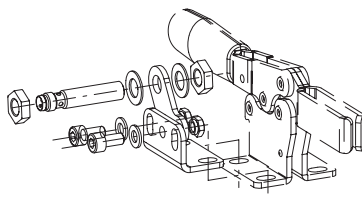

**KSW-B-F**

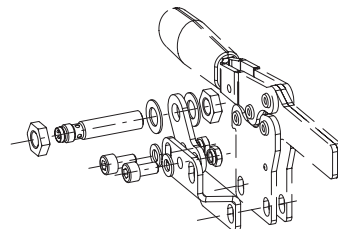

Inductive proximity switch	
<b>Output type</b>	PNP normally open
<b>Voltage range</b>	10-36 V DC
<b>Output indicator</b>	Yellow LED activated
<b>Short circuit/overload indicator</b>	Flashing LED
<b>Working temperature</b>	-25 +80 °C
<b>Protection class</b>	IP 67

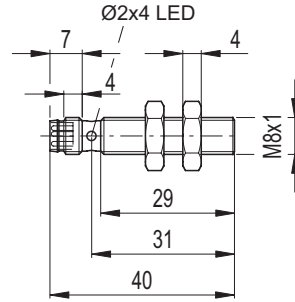

M8 connection

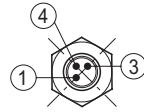

Connection diagram

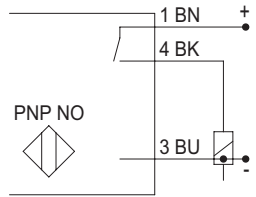

Code	Description	Toggle clamp series	Toggle clamp base	Toggle clamp type	Clamp dimensions
GG.AU800	KSW.130-A-E	Vertical	Folded	MVA / MVAS / MVAS-PR / MVA-R	130
GG.AU804	KSW.230-A-E				230
GG.AU801	KSW.130-B-F	Vertical	Straight	MVB / MVBS / MVBS-PR	130
GG.AU805	KSW.230-B-F				230
GG.AU802	KSW.130-M-O	Horizontal	Folded	MOA / MOAS / MOAS-PR / MOA-R	130
GG.AU806	KSW.230-M-O				230
GG.AU803	KSW.130-N-P	Horizontal	Straight	MOB / MOBS / MOBS-PR	130
GG.AU807	KSW.230-N-P				230

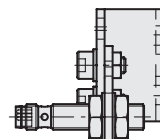
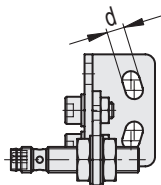
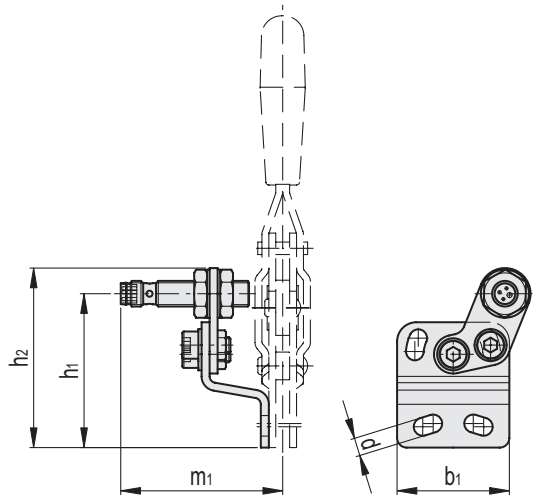
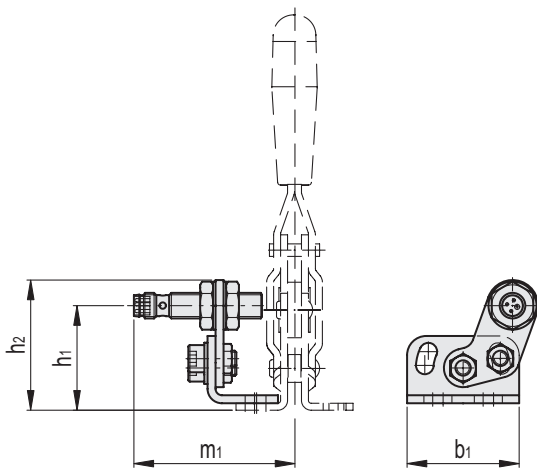

KSW-A-E

INOX STAINLESS STEEL METRIC

Code	Description	b1	d	h1	h2	m1	△
GG.AU800	KSW.130-A-E	35	5.5	33	41	52	67
GG.AU804	KSW. 230-A-E	43	6.5	37	45	54	76

KSW-B-F

INOX STAINLESS STEEL METRIC

Code	Description	b1	d	h1	h2	m1	△
GG.AU801	KSW.130-B-F	35	5.5	48	56	52	76
GG.AU805	KSW. 230-B-F	43	6.5	51	59	53	87



Toggle clamps

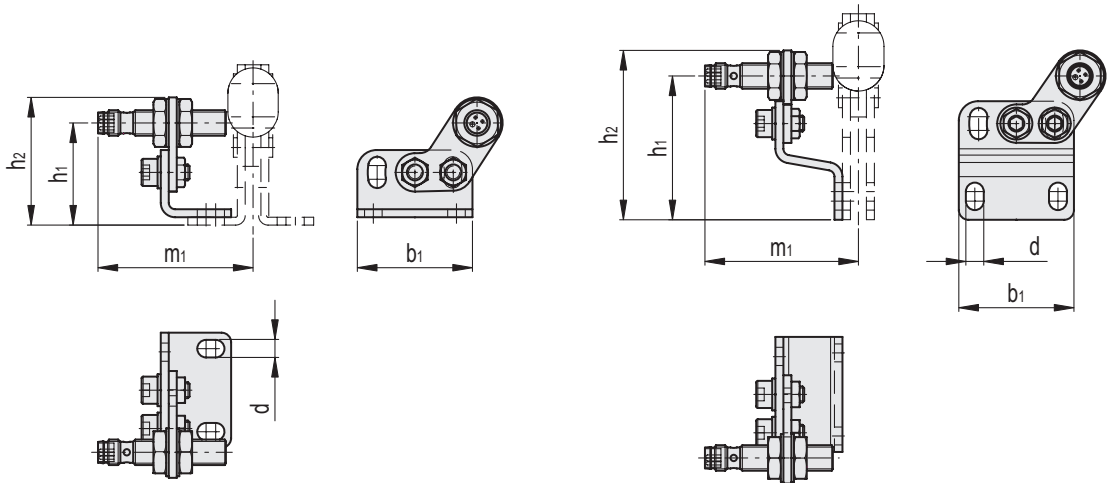

Toggle clamps

3

**KSW-M-O**

**INOX** STAINLESS STEEL **METRIC**

Code	Description	b1	d	h1	h2	m1	$\Delta$
GG.AU802	KSW.130-M-O	36	5.5	32	40	48	68
GG.AU806	KSW.230-M-O	44	6.5	36	44	50	77

**KSW-N-P**

**INOX** STAINLESS STEEL **METRIC**

Code	Description	b1	d	h1	h2	m1	$\Delta$
GG.AU803	KSW.130-N-P	36	5.5	45	53	48	76
GG.AU807	KSW.230-N-P	44	6.5	51	59	50	88