

METRIC

- 1
- 2
- 3
- 4
- 5
- 6
- 7
- 8
- 9
- 10
- 11
- 12
- 13
- 14
- 15
- 16
- 17
- 18
- 19

### ASSEMBLY ENDS

Glass-fibre reinforced polyamide based (PA) technopolymer, resistant to high temperatures, black colour, matte finish.

### SUPPORT

Aluminium in natural colour.

### TRANSPARENT FRONT PROTECTION

Transparent polyamide based technopolymer (PA-T) tile, resistant to high temperatures, high resistance to impacts, solvents, additive oils, aliphatic and aromatic hydrocarbons, petrol, naphtha, phosphoric esters. Avoid contact with detergents containing strong alcohols, glycols, acids or bases.

Can be removed for cleaning if necessary by levering with a screwdriver at the base of the protection to release the retaining undercut (see instructions on the plate).

### LEVEL TUBULAR WINDOW

Borosilicate glass transparent tube.

### GRADUATED CONTRAST SCREEN

White lacquered aluminium. It can be taken out before assembly to allow the insertion of level lines or words.

### SCREWS, NUTS AND WASHERS

AISI 304 stainless steel.

### PACKING RINGS

Red silicone VMQ 70ShA.

Produced from FDA compliant raw material (FDA CFR.21).

### FEATURES

Maximum fluid level visibility even from side positions.

### TECHNICAL DATA

Maximum continuous working temperature: over 160°C at a maximum pressure of 1 bar.

For use with other fluids and under different pressure and temperature conditions, please contact ELESA Technical Department.

In any case we suggest to verify the suitability of the product under the actual working conditions.



ELESA Original design

Drilling template  
Holes without burrs and chamfer

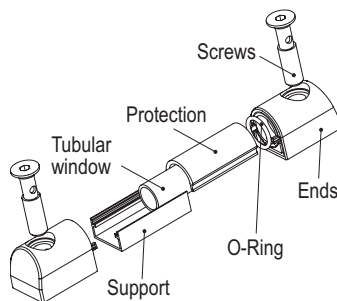
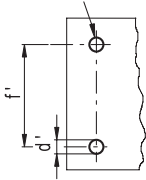

Conversion Table 1 mm = 0.039 inch	
mm	inch
127	4.95
176	6.86
254	9.91
381	14.86
508	19.81

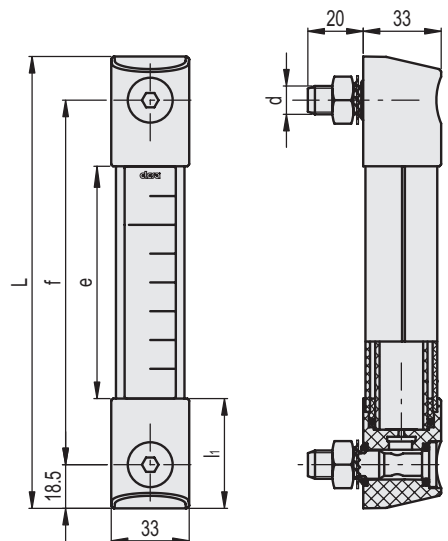

METRIC

Code	Description	f	d	L	e	l1	d'-0.2	f±0.2	C# [Nm]	⚖
111019	HCK.127-HT-SST-M12-VMQ-GL-P	127	M12	164	71	46.5	12.5	127	12	208
111029	HCK.176-HT-SST-M12-VMQ-GL-P	176	M12	213	120	46.5	12.5	176	12	240
111039	HCK.254-HT-SST-M12-VMQ-GL-P	254	M12	291	198	46.5	12.5	254	12	289
111049	HCK.381-HT-SST-M12-VMQ-GL-P	381	M12	418	325	46.5	12.5	381	12	369
111059	HCK.508-HT-SST-M12-VMQ-GL-P	508	M12	545	452	46.5	12.5	508	12	449