

- 1
- 2
- 3
- 4
- 5
- 6
- 7
- 8
- 9
- 10
- 11
- 12
- 13
- 14
- 15
- 16
- 17
- 18
- 19

ASSEMBLY ENDS

Glass-fibre reinforced polyamide based (PA) technopolymer, black colour.

SUPPORT

Aluminium in natural colour.

GRADUATED CONTRAST SCREEN

White lacquered aluminium. It can be taken out before assembly to allow the insertion of level lines or words.

FLOAT

Technopolymer, black colour, with a built-in magnetic element to activate the electric contact when the float reaches the contact threshold located at about 55 mm above the axis of the lower screw (data referred to mineral oil type CB68, according to ISO 3498, temperature 23°C).

SPACER SLEEVES

In polyamide based (PA) technopolymer. Essential in cases where the reservoir is made out of ferromagnetic material in order to prevent the interaction between the magnet and the metal mass of the reservoir.

BRACKET WITH MALE CONNECTOR

Perfectly watertight, incorporating the relay (reed) with two output conductors (NO and NC version) or three conductors (SW version).
 - DIN 43650 C connector in glass-fibre reinforced polyamide based (PA) technopolymer, black colour.
 - 4-pole M12x1 connector, with threading in glass-fibre reinforced polyamide based (PA) technopolymer certified self-extinguishing UL-94-V0, black colour, matte finish.

For a correct assembly see Warnings (on page 1227).

FEMALE CONNECTOR (DIN 43650 C)

With built-in cable gland and contact holder. Front or axial output (high or low) ensuring protection against water sprays (protection class IP 65 according to table EN 60529 on page A-19).

STANDARD EXECUTIONS

See configuration table.

TECHNICAL DATA

In laboratory tests carried out for a relatively limited time with the following liquids at a temperature of 23° C: mineral oil type CB68 (according to ISO 3498) for HCK, mineral oil type CB68 (according to ISO 3498) water or water/glycol-based solutions (50%) for HCK-GL, the resistance values were much higher than 35 bar.

For use with fluids other than mineral oils and under particular different pressure and temperature conditions, please contact ELESA Technical Department.

In any case we suggest to verify the suitability of the product under the actual working conditions.

SPECIAL EXECUTIONS ON REQUEST

- Column level window in transparent methylmethacrylate (PMMA) for max 70°C use.
- Polyamide based technopolymer float (from HCK.127) red colour.
- NBR float (from HCK.176) black colour with AISI 316 stainless steel spiral for special executions, viscous liquids, high temperatures.
- Indicators with level visibility (quota) up to 1429 mm and fixing holes with centre distance (quota f) up to 1500 mm.
- Packing rings in special material depending on the customer's needs.
- Special screw with nickel-plated brass tap to be fitted to the lower assembly end for any maintenance operation requiring the indicator exclusion.

ACCESSORIES ON REQUEST

FC-M12x1: extensions with 4 pole M12 female axial connector.

FEMALE CONNECTOR ASSEMBLY INSTRUCTIONS

1. Remove the connector from the indicator by unscrewing the set screw placed on the connector, take the contact holders out and loosen the cable gland.
2. Insert the cable into the connector (standard connector) and connect the wires to terminals 1 and 2 (NO and NC versions) or 1, 2 and 3 (SW version) of the contact holder. Press fit the contact holder into the connector in the desired position.
3. Screw the connectors to the indicator and then tighten the cable glands.



ELESA Original design

FEATURES AND PERFORMANCES

The HCK-E level indicator with lateral connector output allows the level of intervention of the sensor to be minimised.
 In case of use of an extension with angled connector, the direction of the cable output is shown in Fig.1.

Fig.1

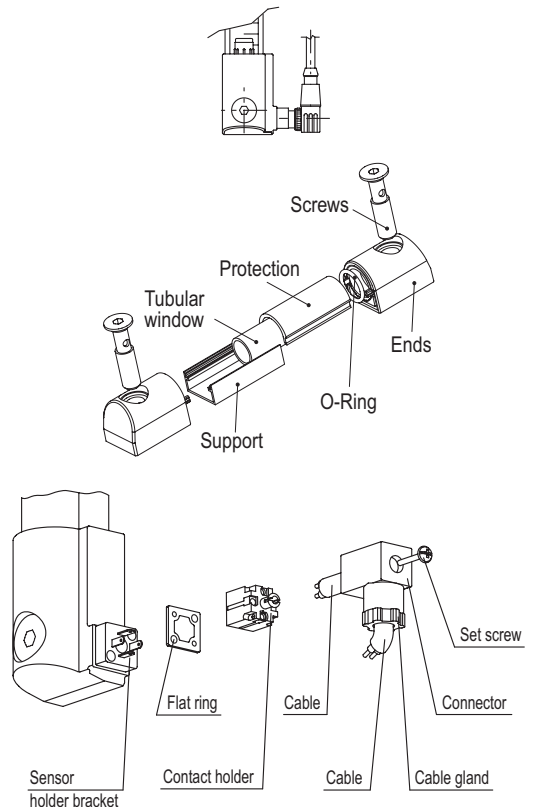

FUNCTIONING OF THE MIN LEVEL ELECTRICAL SENSOR

- NO: the electrical contact closes on reaching the minimum level.
- NC: the electrical contact is opened when it reaches the minimum level.
- SW (change-over electrical contact): the electrical contact switches between the two terminals.

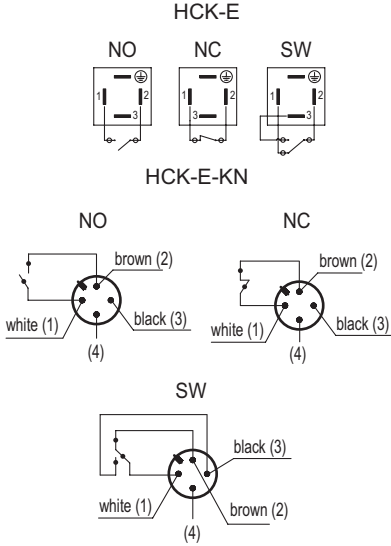

*The colours refer to the use of the FC M12x1 extension

TABLE FOR STANDARD EXECUTIONS SET-UP



① Centre distance (f)	127	127 mm
	176	176 mm
	254	254 mm
	381	381 mm
	508	508 mm

② Screws, nuts and washers	ZN	Zinc-plated steel.
	SST	Steel screws, nuts and washers. AISI 304 stainless steel.
	A4	AISI 316 stainless steel.

③ Packing rings	NBR	O-Ring in NBR synthetic rubber for use with a maximum continuous operating temperature of 100°C.
	FKM	O-Ring in VITON® FKM synthetic rubber for use with a maximum continuous operating temperature of 130°C.

④ Tubular bubble level	PC	Transparent polycarbonate tube for use with oil.
	GL	Transparent borosilicate glass tube for use with oil, water, or water/glycol solutions (50%).

VITON® Registered trademark by DuPont Dow Elastomers.

HCK-E - HCK-E-KN	
Electrical features	MIN level sensor
Power supply	AC/DC
Electric contacts	NO normally open
	NC normally closed
	SW change-over contact
Maximum applicable voltage	NO: 140 Vac, 200 Vdc
	NC: 140Vac, 150 Vdc
	SW: 140Vac, 150 Vdc
	DIN 43650 C
	30 Vac, 30 Vdc
	KN
Voltage range (Type KN)	<30 Vac, <30 Vdc
Maximum switching current	1 A
Maximum current	NO: 1.2A
	NC: 2A
	SW: 2A
Maximum commutable power	NO: 10 Va
	NC: 20 Va
	SW: 20 Va
Cable gland (only HCK-E)	Pg 7 (for cables in sheath with Ø 6 or 7 mm)
Conductors cross-section (only HCK-E)	Max. 1.5 mm ²
Connector (only HCK-E-KN)	M12x1
Do not mount this indicator in proximity to magnetic fields.	

Transparent front protection	P	Polycarbonate (PC) plate. Removable for cleaning.
------------------------------	---	---

⑤ MIN level sensor	E	Float in polypropylene-based (PP) technopolymer, maximum continuous operating temperature 80°C.
	EHT #	Float in glass-fibre reinforced polyamide based (PA) technopolymer, maximum continuous operating temperature 120°C.

⑥ MIN level electrical contact.	NO	Normally open electrical contact that closes when the MIN level is reached.
	NC	Normally closed electrical contact that opens when the MIN level is reached.
	SW	Electrical exchange contact that switches between the two terminals.

⑦ Connector		DIN 43650 C, adjustable front or side output.
	KN	4-pole male M12x1

For execution FKM in paragraph 3.

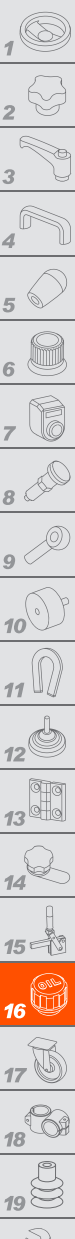

Accessories for hydraulic systems

- 1
- 2
- 3
- 4
- 5
- 6
- 7
- 8
- 9
- 10
- 11
- 12
- 13
- 14
- 15
- 16
- 17
- 18
- 19

Spacers

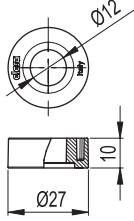

Drilling template
Holes without burrs and chamfer

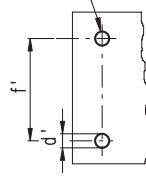

HCK-E

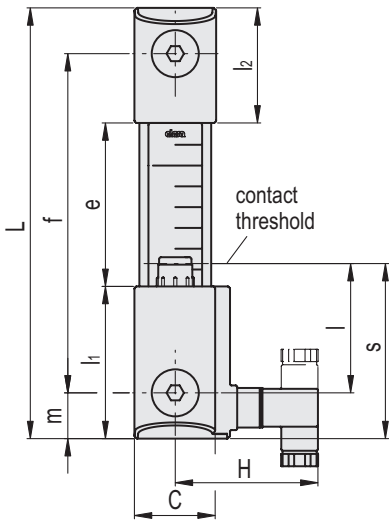

HCK-E-KN

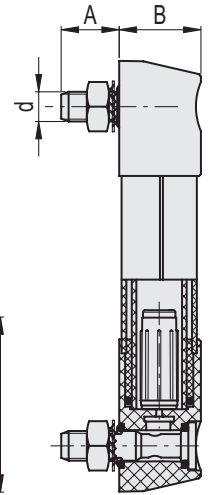
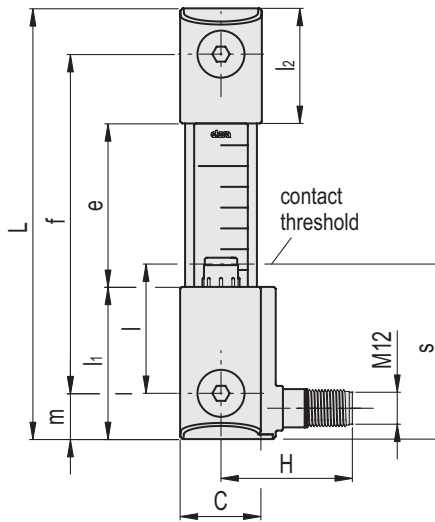

Conversion Table 1 mm = 0.039 inch	
f	
mm	inch
127	4.95
176	6.86
254	9.91
381	14.86
508	19.81

METRIC

HCK-E																
f	d	A	B	C	H	L	e	l	l1	l2	m	s	d-0.2	f±0.2	C#	⚖
127	M12	20	33	33	59	164	56	55	61.5	46.5	18.5	73.5	12.5	127	12	228
176	M12	20	33	33	59	213	105	55	61.5	46.5	18.5	73.5	12.5	176	12	258
254	M12	20	33	33	59	291	183	55	61.5	46.5	18.5	73.5	12.5	254	12	305
381	M12	20	33	33	59	418	310	55	61.5	46.5	18.5	73.5	12.5	381	12	384
508	M12	20	33	33	59	545	437	55	61.5	46.5	18.5	73.5	12.5	508	12	462

HCK-E-KN																
f	d	A	B	C	H	L	e	l	l1	l2	m	s	d-0.2	f±0.2	C#	⚖
127	M12	20	33	33	47	164	56	55	61.5	46.5	18.5	73.5	12.5	127	12	228
176	M12	20	33	33	47	213	105	55	61.5	46.5	18.5	73.5	12.5	176	12	258
254	M12	20	33	33	47	291	183	55	61.5	46.5	18.5	73.5	12.5	254	12	305
381	M12	20	33	33	47	418	310	55	61.5	46.5	18.5	73.5	12.5	381	12	384
508	M12	20	33	33	47	545	437	55	61.5	46.5	18.5	73.5	12.5	508	12	462

Maximum tightening torque.