

- 1
- 2
- 3
- 4
- 5
- 6
- 7
- 8
- 9
- 10
- 11
- 12
- 13
- 14
- 15
- 16
- 17
- 18
- 19

ASSEMBLY ENDS

Glass-fibre reinforced polyamide based (PA) technopolymer, black colour.

SUPPORT

Aluminium in natural colour.

GRADUATED CONTRAST SCREEN

White lacquered aluminium. It can be taken out before assembly to allow the insertion of level lines or words.

FLOAT

Technopolymer, black colour, with a built-in magnetic element to activate the electric contact when the float reaches the contact threshold located at about 55 mm above the axis of the lower screw (data referred to mineral oil type CB68, according to ISO 3498, temperature 23°C).

SPACER SLEEVES

In polyamide based (PA) technopolymer. Essential in cases where the reservoir is made out of ferromagnetic material in order to prevent the interaction between the magnet and the metal mass of the reservoir.

BRACKET WITH MALE CONNECTOR

Perfectly watertight, incorporating the relay (reed) with two output conductors (NO and NC version) and/or with MAX temperature sensor (80°C) and/or temperature probe.

- DIN 43650 C connector in glass-fibre reinforced polyamide based (PA) technopolymer, black colour.
- 4-pole M12x1 connector, with threading in glass-fibre reinforced polyamide based (PA) technopolymer certified self-extinguishing UL-94-V0, black colour, matte finish.

For a correct assembly see Warnings (on page 1227).

FEMALE CONNECTOR (DIN 43650 C)

With built-in cable gland and contact holder. Front or axial output (high or low) ensuring protection against water sprays (protection class IP 65 according to table EN 60529 on page A-19).

STANDARD EXECUTIONS

See configuration table.

TECHNICAL DATA

In laboratory tests carried out for a relatively limited time with the following liquids at a temperature of 23° C: mineral oil type CB68 (according to ISO 3498) for HCK, mineral oil type CB68 (according to ISO 3498) water or water/glycol-based solutions (50%) for HCK-GL, the resistance values were much higher than 35 bar. For use with fluids other than mineral oils and under particular different pressure and temperature conditions, please contact ELESa Technical Department.

In any case we suggest to verify the suitability of the product under the actual working conditions.

SPECIAL EXECUTIONS ON REQUEST

- Column level window in transparent methylmethacrylate (PMMA) for max 70°C use.
- Polyamide based technopolymer float (from HCK.127) red colour.
- NBR float (from HCK.176) black colour with AISI 316 stainless steel spiral for special executions, viscous liquids, high temperatures.
- Indicators with level visibility (quota f) up to 1429 mm and fixing holes with centre distance (quota f) up to 1500 mm.
- Packing rings in special material depending on the customer's needs.
- Special screw with nickel-plated brass tap to be fitted to the lower assembly end for any maintenance operation requiring the indicator exclusion.

ACCESSORIES ON REQUEST

FC-M12x1: extensions with 4 pole M12 female axial connector.

FEMALE CONNECTOR ASSEMBLY INSTRUCTIONS

1. Remove the connector from the indicator by unscrewing the set screw placed on the connector, take the contact holders out and loosen the cable gland.
2. a) HCK-E-ST: insert the cable into the connector (standard connector) and connect the wires to terminals 1 and 2 for the operation of the MIN level sensor, to terminals 3 and ground (4) for the operation of the MAX temperature sensor. b) HCK-E-STL: insert the cable into the connector (standard connector) and connect the wires to terminals 1 and 2 for the operation of the MIN level sensor, to terminals 3 and ground (4) for the operation of the temperature probe.
3. Assemble by pressing the contact holder into the connector in the required position.
4. Screw the connectors to the indicator and then tighten the cable glands.



ELESa Original design

FEATURES AND PERFORMANCES

The HCK-E-S level indicator with lateral connector output allows the level of intervention of the sensor to be minimised.

In case of use of an extension with angled connector, the direction of the cable output is shown in Fig.1.

Fig.1

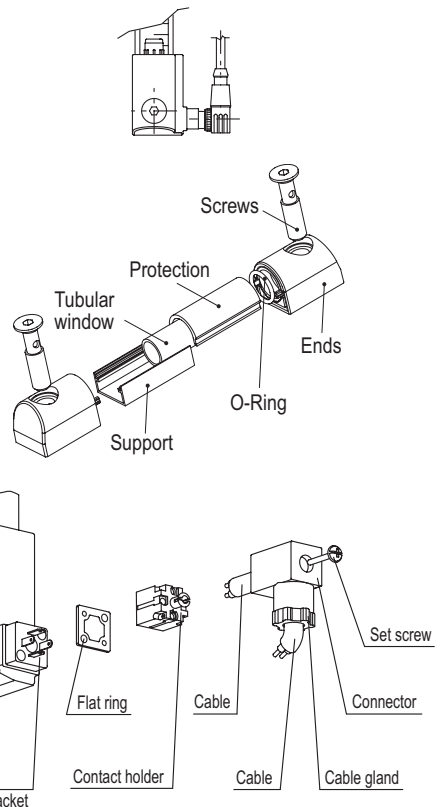

FUNCTIONING OF THE MIN LEVEL ELECTRICAL SENSOR

- NO: the electrical contact closes on reaching the minimum level.
- NC: the electrical contact is opened when it reaches the minimum level.

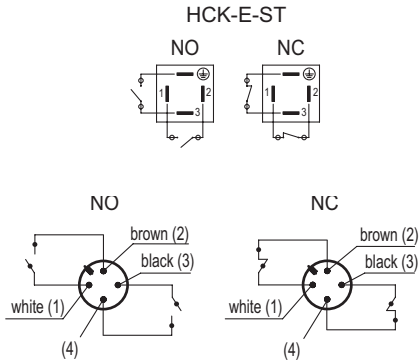

*The colours refer to the use of the FC M12x1 extension
 ** contact 1, 2 electric level sensor

FUNCTIONING OF THE MAX TEMPERATURE SENSOR

- NO: the electrical contact closes when the pre-set temperature is reached at 80°C.
- NC: the electrical contact opens when the pre-set temperature at 80°C is reached.

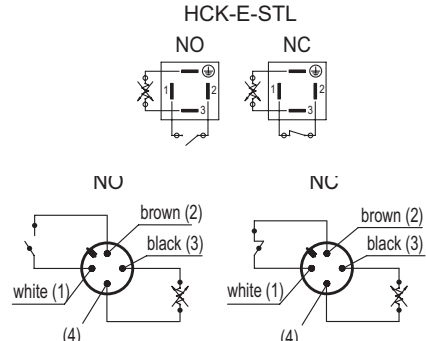

*The colours refer to the use of the FC M12x1 extension
 ** contact 1, 2 electric level sensor

HCK-E-ST - HCK-E-ST-KN	
Electrical features	MIN level sensor
Power supply	AC/DC
Electric contacts	NO normally open NC normally closed
Maximum applicable voltage	NO: 140 Vac, 200 Vdc NC: 140Vac, 150 Vdc
Maximum switching current	1 A
Maximum current	NO: 1.2A NC: 2A
Maximum commutable power	NO: 10 Va NC: 20 Va
Cable gland (only HCK-E-ST)	Pg 7 (for cables in sheath with Ø 6 or 7 mm)
Conductors cross-section (only HCK-E-ST)	Max. 1.5 mm ²
Connector (only HCK-E-ST-KN)	M12x1
Do not mount this indicator in proximity to magnetic fields.	

HCK-E-STL - HCK-E-STL-KN	
Electrical features	MIN level sensor
Power supply	AC/DC
Electric contacts	NO normally open NC normally closed
Maximum applicable voltage	NO: 140 Vac, 200 Vdc NC: 140Vac, 150 Vdc
Maximum switching current	1 A
Maximum current	NO: 1.2A NC: 2A
Maximum commutable power	NO: 10 Va NC: 20 Va
Cable gland (only HCK-E-STL)	Pg 7 (for cables in sheath with Ø 6 or 7 mm)
Conductors cross-section (only HCK-E-STL)	Max. 1.5 mm ²
Connector (only HCK-E-STL-KN)	M12x1
Do not mount this indicator in proximity to magnetic fields.	

HCK-E-ST - HCK-E-ST-KN		
Electrical features	MAX temperature sensor	
Power supply	AC/DC	
Electric contacts	NO normally open NC normally closed	
Voltage / Maximum current	250 Vac - 2 A	(resistive loads)
	115 Vac - 3 A	
	24 Vdc - 3 A	
	12 Vdc - 4 A	
Minimum current	500 mA	
Cable gland (only HCK-E-ST)	Pg 7 (for cables in sheath with Ø 6 or 7 mm)	
Conductors cross-section (only HCK-E-ST)	Max. 1.5 mm ²	
Connector (only HCK-E-ST-KN)	M12x1	
Do not mount this indicator in proximity to magnetic fields.		

HCK-E-STL - HCK-E-STL-KN	
Electrical features	Temperature probe
Power supply	AC/DC
Maximum current	1mA
Cable gland (only HCK-E-STL)	Pg 7 (for cables in sheath with Ø 6 or 7 mm)
Conductors cross-section (only HCK-E-STL)	Max. 1.5 mm ²
Connector (only HCK-E-STL-KN)	M12x1
Do not mount this indicator in proximity to magnetic fields.	

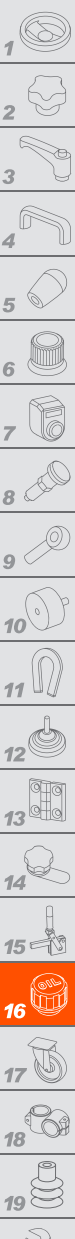

Accessories for hydraulic systems

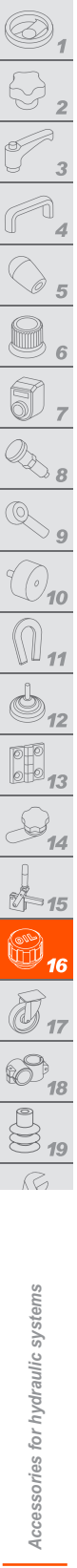

1 FUNCTIONING OF THE TEMPERATURE ELECTRICAL PROBE (STL)

The working principle of the temperature probe is to measure the variation of resistance of a platinum element: 100 ohm = 0°C, 138.4 ohm = 100°C.

The function between temperature (T) and resistance (R) is approximately linear over a small temperature range: for example, if you assume that it is linear over the 0° to 100°C range, the error at 50°C is 0.4°C.

For precision measurement, it is necessary to linearise the resistance to give an accurate temperature. The most recent definition of the function between resistance and temperature is International Temperature Standard 90 (ITS-90). The function between resistance and temperature, obtained in laboratory tests, measuring directly the resistance value on the contacts is shown in the graph. We suggest, anyway, to set the system in order to compensate both heat dissipation and cable resistance.

The temperature variation of 1°C causes a 0.384 ohm variation in the probe resistance. Therefore, even a small error in the resistance measurement (for example, if the resistance of the cables connecting to the probe were not considered) translates into a significant error in the temperature measurement.

Because of the low signal levels, it is important to keep any cables away from electric cables, motors, switchgear and other devices that may emit magnetic or electrical noise. Using screened cable, with the screen grounded at one end, may help to reduce interference.

Furthermore, if long connection cables are used, make sure that the signal measurement and reception device is designed to compensate for the resistance of the cables themselves.

Resistance / temperature conversion graph

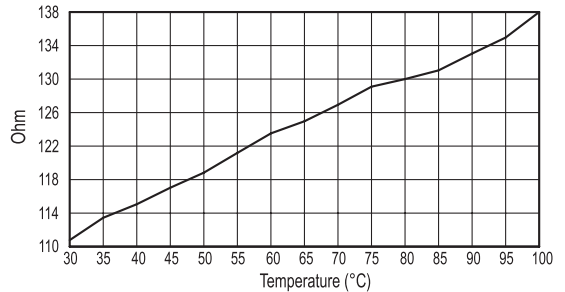

TABLE FOR STANDARD EXECUTIONS SET-UP

HCK.	-	127	-	ZN	M12	-	NBR	-	PC	-	P	-	E	-	NO	-	80-NO	-	KN
		①		②			③		④				⑤		⑥		⑦		⑧

①	Centre distance (f)	127	127 mm
		176	176 mm
		254	254 mm
		381	381 mm
		508	508 mm

②	Screws, nuts and washers	ZN	Zinc-plated steel.
		SST	AISI 304 stainless steel screws, nuts and washers.
		A4	AISI 316 stainless steel.

③	Packing rings	NBR	O-Ring in NBR synthetic rubber for use with a maximum continuous operating temperature of 100°C.
		FKM	O-Ring in VITON® FKM synthetic rubber for use with a maximum continuous operating temperature of 130°C.

④	Tubular bubble level	PC	Transparent polycarbonate tube for use with oil.
		GL	Transparent borosilicate glass tube for use with oil, water, or water/glycol solutions (50%).

Transparent front protection	P	Polycarbonate (PC) plate. Removable for cleaning.
------------------------------	---	---

⑤	MIN level sensor	E	Float in polypropylene-based (PP) technopolymer, maximum continuous operating temperature 80°C.
		EHT #	Float in glass-fibre reinforced polyamide based (PA) technopolymer, maximum continuous operating temperature 120°C.

⑥	MIN level electrical contact.	NO	Normally open electrical contact that closes when the MIN level is reached.
		NC	Normally closed electrical contact that opens when the MIN level is reached.

⑦	Temperature Sensor / Probe	80-NO *	MAX temperature electrical sensor (80°C) with normally open electrical contacts. (ST version)
		80-NC **	MAX temperature electrical sensor (80°C) with normally closed electrical contacts. (ST version)
		STL ***	PT 100 temperature electrical probe.

⑧	Connector		DIN 43650 C, adjustable front or side output.
		KN	4-pole male M12x1

For execution FKM in paragraph 3.
 * For execution NO in paragraph 6.
 ** For execution NC in paragraph 6.
 *** For executions NO and NC in paragraph 6.

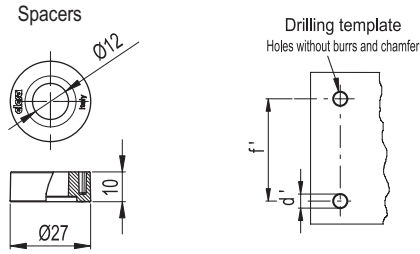

HCK-E-ST
HCK-E-STL

HCK-E-ST-KN
HCK-E-STL-KN

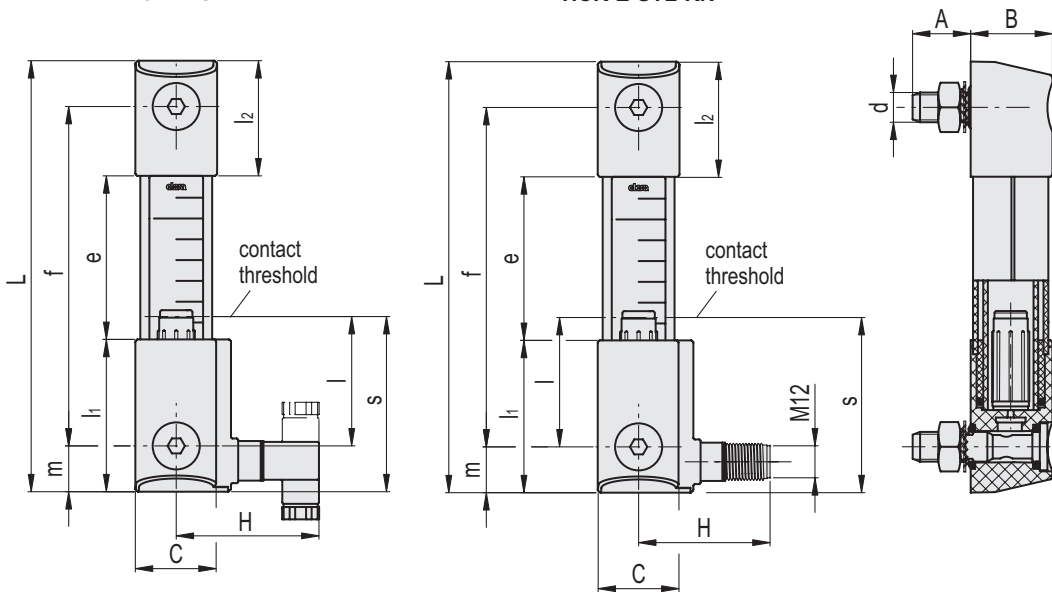

Conversion Table
1 mm = 0.039 inch

f	
mm	inch
127	4.95
176	6.86
254	9.91
381	14.86
508	19.81

METRIC

HCK-E-ST - HCK-E-STL

f	d	A	B	C	H	L	e	l	l1	l2	m	s	d'-0.2	f±0.2	C#	[Nm]	⚖️
127	M12	20	33	33	59	164	56	55	61.5	46.5	18.5	73.5	12.5	127	12	228	
176	M12	20	33	33	59	213	105	55	61.5	46.5	18.5	73.5	12.5	176	12	258	
254	M12	20	33	33	59	291	183	55	61.5	46.5	18.5	73.5	12.5	254	12	305	
381	M12	20	33	33	59	418	310	55	61.5	46.5	18.5	73.5	12.5	381	12	384	
508	M12	20	33	33	59	545	437	55	61.5	46.5	18.5	73.5	12.5	508	12	462	

HCK-E-ST-KN - HCK-E-STL-KN

f	d	A	B	C	H	L	e	l	l1	l2	m	s	d'-0.2	f±0.2	C#	[Nm]	⚖️
127	M12	20	33	33	47	164	56	55	61.5	46.5	18.5	73.5	12.5	127	12	228	
176	M12	20	33	33	47	213	105	55	61.5	46.5	18.5	73.5	12.5	176	12	258	
254	M12	20	33	33	47	291	183	55	61.5	46.5	18.5	73.5	12.5	254	12	305	
381	M12	20	33	33	47	418	310	55	61.5	46.5	18.5	73.5	12.5	381	12	384	
508	M12	20	33	33	47	545	437	55	61.5	46.5	18.5	73.5	12.5	508	12	462	

Maximum tightening torque.

