

MATERIAL

Cast aluminium or die-cast zinc alloy, epoxy resin coating, RAL 9005 black colour, matte finish.

STANDARD EXECUTIONS

Revolving handle in polyamide based (PA) technopolymer, black colour, matte finish.

- **GN 471-B:** cast aluminium, reamed hole.
- **GN 471-V:** cast aluminium, square hole.
- **GN 471.1-B:** zinc alloy, reamed hole.
- **GN 471.1-V:** zinc alloy, square hole.

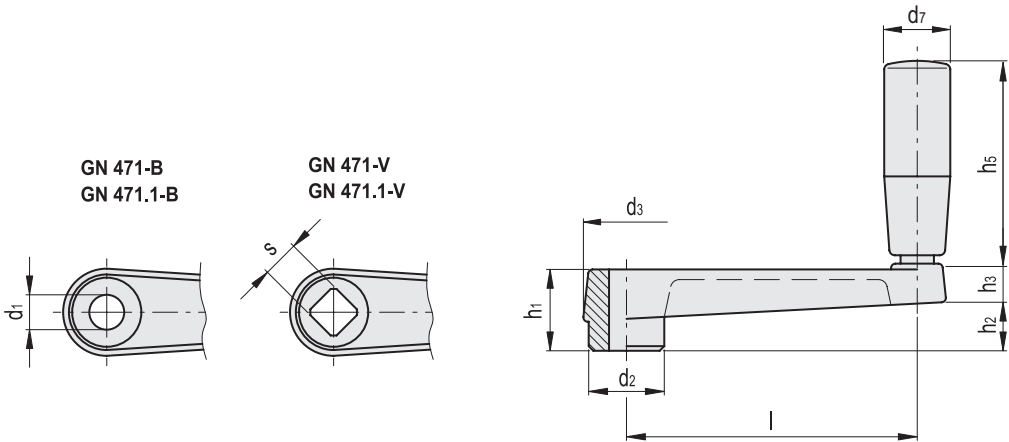

GN 471

INCH

Code	Description	l	d1	s	d2	d3	h1	h2	h3	h5	d7	Δ
GN.922511	GN 471-80-B3/8	3.15	0.375	-	0.91	1.02	0.94	0.55	0.55	2.07	0.83	0.22
GN.922512	GN 471-80-V3/8	3.15	-	0.375	0.91	1.02	0.94	0.55	0.55	2.07	0.83	0.22
GN.922521	GN 471-100-B1/2	3.94	0.500	-	1.06	1.18	1.1	0.67	0.59	2.66	0.91	0.37
GN.922522	GN 471-100-V1/2	3.94	-	0.500	1.06	1.18	1.1	0.67	0.59	2.66	0.91	0.37
GN.922531	GN 471-125-B5/8	4.92	0.625	-	1.26	1.38	1.34	0.87	0.71	3.25	1.02	0.56
GN.922532	GN 471-125-V5/8	4.92	-	0.625	1.26	1.38	1.34	0.87	0.71	3.25	1.02	0.55
GN.922541	GN 471-160-B3/4	6.3	0.750	-	1.38	1.54	1.5	1.02	0.71	3.25	1.02	0.7
GN.922542	GN 471-160-V3/4	6.3	-	0.750	1.38	1.54	1.5	1.02	0.71	3.25	1.02	0.69

GN 471.1

INCH

Code	Description	l	d1	s	d2	d3	h1	h2	h3	h5	d7	Δ
GN.922501	GN 471.1-64-B1/2	2.52	0.500	-	0.75	0.87	0.79	0.43	0.47	1.67	0.71	0.22
GN.922502	GN 471.1-64-V3/8	2.52	-	0.375	0.75	0.87	0.79	0.43	0.47	1.67	0.71	0.21