

CFDA | Hinges for narrow jamb

SUPER-technopolymer



- 1
- 2
- 3
- 4
- 5
- 6
- 7
- 8
- 9
- 10
- 11
- 12
- 13
- 14
- 15
- 16
- 17
- 18

MATERIAL

Glass-fibre reinforced polyamide based (PA) SUPER-technopolymer, black colour, matte finish.

ROTATING PIN

AISI 303 stainless steel.

STANDARD EXECUTION

Pass-through holes for countersunk head screws.

FEATURES AND APPLICATIONS

The hinge is made up of two bodies of different sizes (one wide and one narrow) for use, for example, on structures with a narrow jamb.

ROTATION ANGLE (APPROXIMATE VALUE)

Max 215° (-5° and +210° being 0° the condition where the two interconnected surfaces are on the same plane).

Do not exceed the rotation angle limit so as not to prejudice the hinge mechanical performance.

To choose the convenient type and the right number of hinges for your application, see the Guidelines (see page 1298).



ELESA Original design

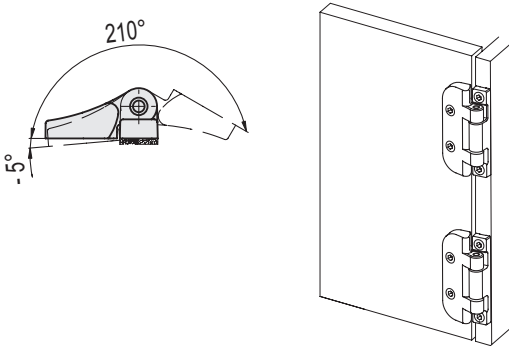

Resistance tests	Axial Stress		Radial Stress		90° Angled Stress	
	Maximum working load Ea [N]	Load at breakage Ra [N]	Maximum working load Er [N]	Load at breakage Rr [N]	Maximum working load E90 [N]	Load at breakage R90 [N]
CFDA.72 SH-4	200	2900	400	1400	400	1600
CFDA.100 SH-5	400	3200	400	1800	800	1800

Conversion Table	
1 mm = 0.039 inch	
mm	inch
72	2.83
100	3.94

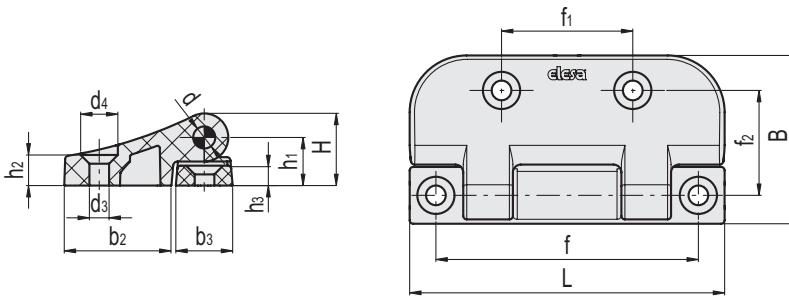

Code	Description	L	B	f±0.25	f1±0.25	f2±0.25	H	h1	h2	h3	b2	b3	d	d3	d4	C# [Nm]	⚠
423081	CFDA.72 SH-4	72	38.5	60	30	24	16.5	11	7	6.5	24.5	13	5	4.5	8.5	3	38
423091	CFDA.100 SH-5	100	46.5	84	40	30	19.5	13	8	7.5	30.5	15	6	5.5	10.5	4	73

Hinges and accessories

2

Suggested tightening torque for assembly screws.

