

- 1
- 2
- 3
- 4
- 5
- 6
- 7
- 8
- 9
- 10
- 11
- 12
- 13
- 14
- 15
- 16
- 17
- 18

MATERIAL

Polyamide based (PA) technopolymer, black colour, matte finish.

STANDARD EXECUTIONS

- **BTL-B**: brass boss, threaded blind hole.
- **BTL-p**: zinc-plated steel threaded stud, chamfered flat end according to UNI 947 : ISO 4753 (see Technical data on page A-11).



ELESA Original design

Conversion Table	
1 mm = 0.039 inch	
D	
mm	inch
20	0.79
26	1.01
32	1.26

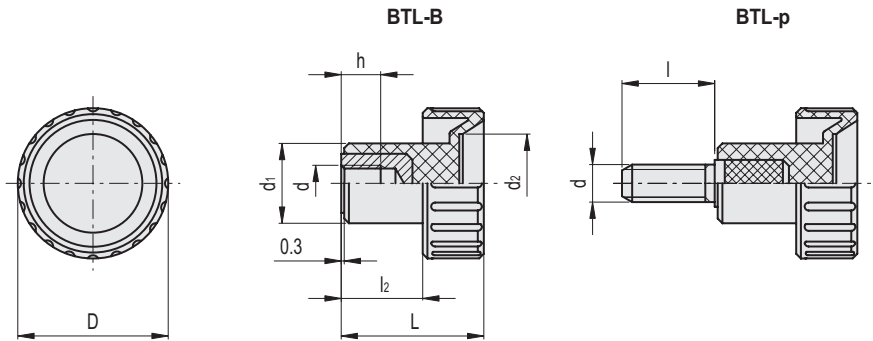

BTL-B

METRIC

Code	Description	D	d6H	L	d1	d2	l2	h	△
6401	BTL.20 B-M5	20	M5	21	11	11	12	10	6
6402	BTL.20 B-M6	20	M6	21	11	11	12	12	7
6431	BTL.25 B-M6	26	M6	26	16	15	15	12	10
6432	BTL.25 B-M8	26	M8	26	16	15	15	13	9
6462	BTL.32 B-M8	32	M8	30	17	21	17	15	13

BTL-p

METRIC

Code	Description	D	d6g	L	d1	d2	l	l2	△
6411	BTL.20 p-M6x16	20	M6	21	11	11	16	12	11
6441	BTL.25 p-M8x20	26	M8	26	16	15	20	15	11
6471	BTL.32 p-M8x25	32	M8	30	17	21	25	17	31

Clamping elements