

- 1
- 2
- 3
- 4
- 5
- 6
- 7
- 8
- 9
- 10
- 11
- 12
- 13
- 14
- 15
- 16
- 17
- 18
- 19

**MATERIAL**

Shaft locking base in polyamide based (PA) SUPER-technopolymer, black colour, matte finish.

Hexagon head screws in AISI 316 stainless steel.

Adjustable handle ERW. Glass-fibre reinforced polyamide based (PA) technopolymer, grey-black colour, matte finish, with AISI 304 stainless steel boss, threaded blind hole.

**FEATURES AND APPLICATIONS**

BSA-T50 locking bases allow an easy and quick locking of the spindles after their positioning.

They are equipped with a DIA 0.24 (Ø 6.1 mm) hole to fit the referring pin of the indicator.

They can be assembled with the handle either on the right or on the left and can be fitted to the machine by means of two M3 cylindrical-head screws (not included in the supply).

Thanks to the use of stainless steel and completely technopolymer parts, it can be subjected to frequent washing and used in any situation or environment where particular attention to cleanliness and hygiene is required, such as for example food packaging or bottling machines.

Furthermore, since there are no surface treatments that can deteriorate over time (for example varnishing), the characteristics of the product remain unchanged during its use.



ELESA Original design

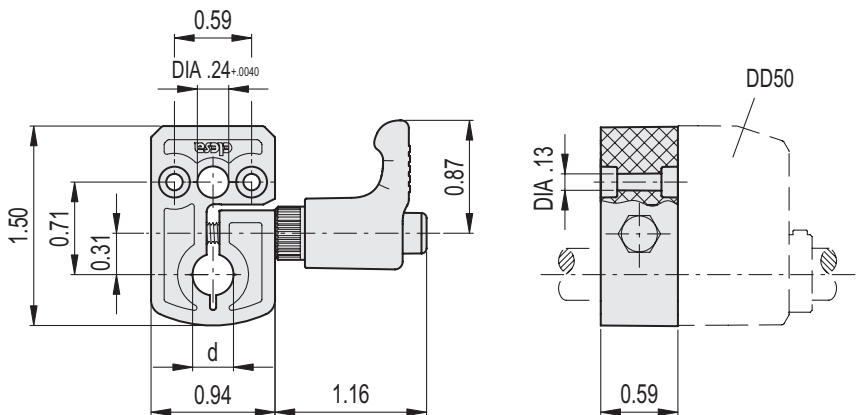

Code	Description	d	⚖
CE987951	BSA-T50-1/4-SST	0.250	0.055
CE987953	BSA-T50-3/8-SST	0.375	0.054