

- 1
- 2
- 3
- 4
- 5
- 6
- 7**
- 8
- 9
- 10
- 11
- 12
- 13
- 14
- 15
- 16
- 17
- 18

MATERIAL

Die-cast zinc alloy bases for spindle locking, epoxy resin coating, black colour, matte finish.

GN 302.1 adjustable handle with lever body in die-cast zinc alloy, black colour and AISI 303 stainless steel clamping element.

FEATURES AND APPLICATIONS

BSA-N51 locking bases allow an easy and quick locking of the spindles after their positioning. They are equipped with a Ø 6.1 mm hole to fit the referring pin of the indicator. They can be assembled with the handle either on the right or on the left and can be fitted to the machine by means of two M4 cylindrical-head screws (not included in the supply).

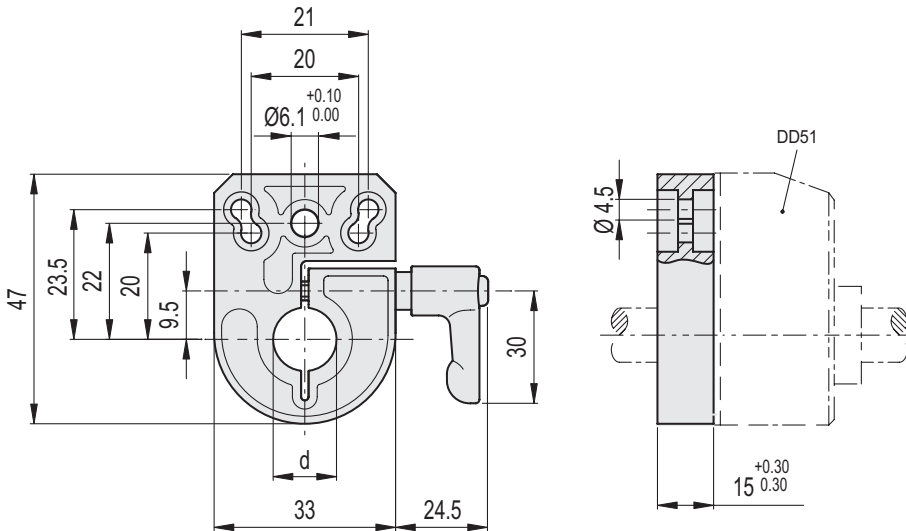

Code	Description	dF9	Δ
CE.85915	BSA-N51-8	8	107
CE.85917	BSA-N51-10	10	104
CE.85919	BSA-N51-12	12	101
CE.85921	BSA-N51-14	14	98