

- 1
- 2
- 3
- 4
- 5
- 6
- 7
- 8
- 9
- 10
- 11
- 12
- 13
- 14
- 15
- 16
- 17
- 18

MATERIAL

Polyamidbaserad teknopolymer (PA), grå färg.

SKRUV OCH MUTTER

AISI 304 rostfritt stål.

KÄNNETECKEN OCH ANVÄNDNING

TGL ändavslut används vid ändarna av GLA sidorullstyrningar (Fig.1) och GCA centrala rullstyrningar (Fig. 2).

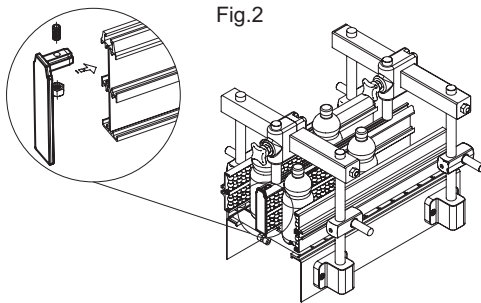
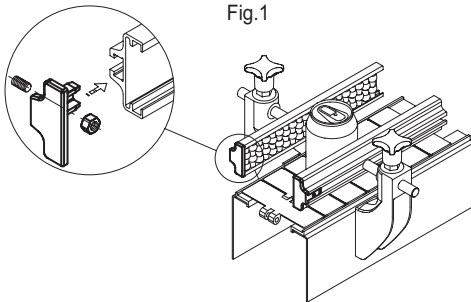
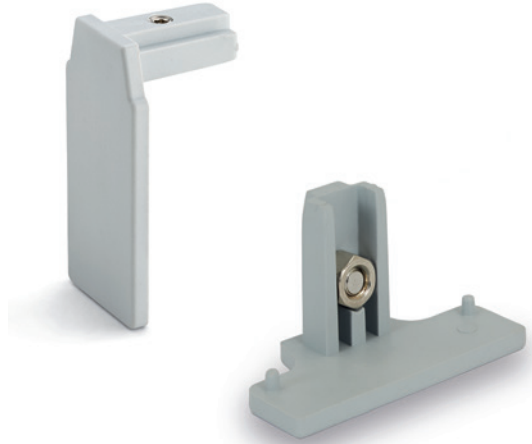

TGL-24-48
TGL-24-93

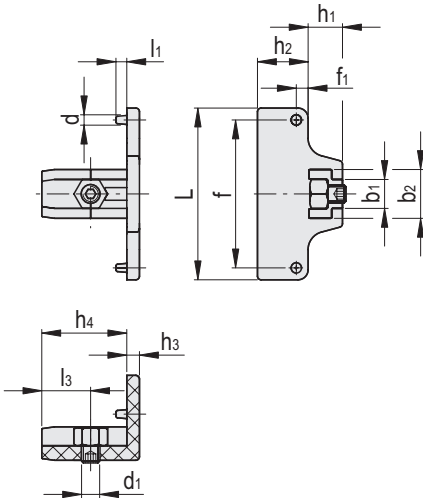

TGL-57-26
TGL-99-26

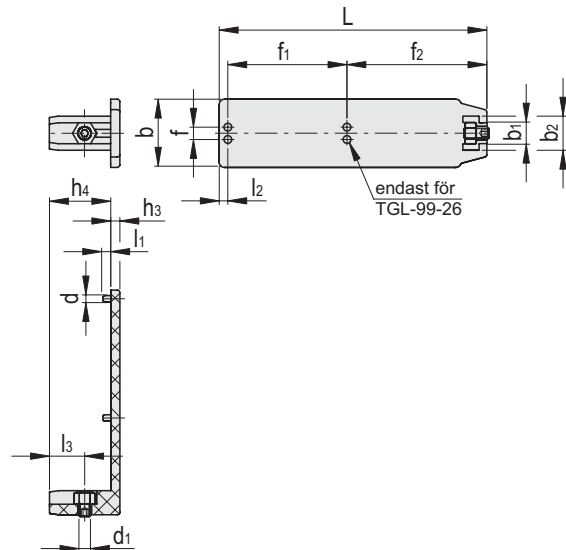

Kod	Benämning	d	d1	f1	L	f	f2	b	b1	b2	h1	h2	h3	h4	l1	l2	l3	Δ
419143	TGL-24-48	2.5	M5	3.2	47.5	40.9	-	-	8	13.5	9.5	14	3.5	23.5	3	-	13.5	10
419144	TGL-24-93	2.5	M5	3.2	93	86	-	-	8	13	9.5	14	3.5	23.5	3	-	13.5	16
419142	TGL-57-26	2.5	M5	-	57.4	4.7	-	26.2	8	13	-	-	3.5	23.5	3	3.3	13.5	11
419140	TGL-99-26	2.5	M5	45.7	102.7	4.7	53.7	26.2	8	13	-	-	3.5	23.5	3	3.3	13.5	17