

**SIDOSTYRNINGSPROFIL**

AISI 304 rostfritt stål med teknopolymerbeläggning (PEEK), grå färg.

**KONSOL**

Anodiserat aluminium.

**KÄNNETECKEN OCH ANVÄNDNING**

GCF mittstyrningar används vanligtvis för att på transportband styra buntar av värmekrympbar polyetenfilm i sidled. PEEK-beläggningen garanterar minimalt rullmotstånd för produkten. Lämplig för användning vid höga temperaturer.

Beläggningstjocklek: minst 40 µ, maximalt 50 µ.

Levereras i stänger av 1500 eller 3000 mm längd.

**TILLBEHÖR PÅ FÖRFRÅGAN**

- BDG: skarvskena för rullstyrningar.
- TGLF: ändavslut för sidorullstyrningar.
- GGLF: skarv för linjär styrning.
- PGC-2: separationsenhet för centrala rullstyrningar.
- MPG-P: styrtapp.
- MPG-V: skruv med hammarhuvud stålplåt.

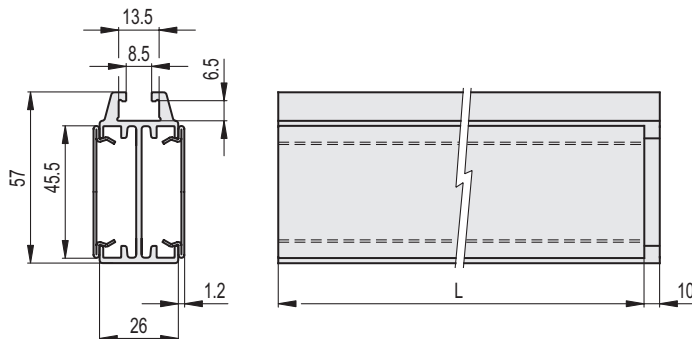
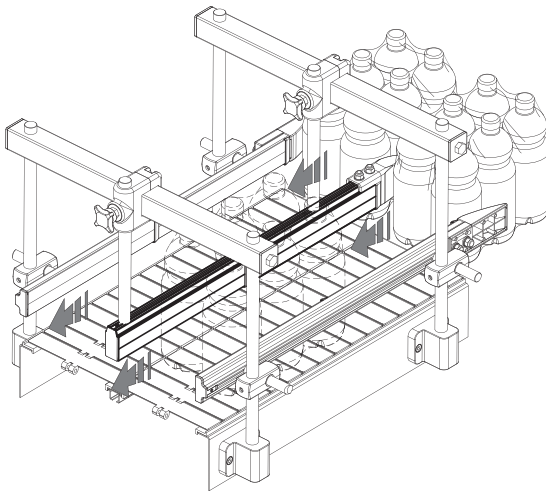

Kod	Benämning	L	△
419091	GCF-46-1500	1500	2250
419092	GCF-46-2990	2990	4500