

**MATERIALE**

Ventosa in gomma antiolio (NBR), naturale (NR) o siliconica (VMQ).
Supporto in alluminio anodizzato.

**ESECUZIONI STANDARD**

- VVP-50-T-A: gomma antiolio.
- VVP-50-T-N: gomma naturale.
- VVP-50-T-S: gomma siliconica.

**CARATTERISTICHE E APPLICAZIONI**

Sono specificatamente indicate per prelevare fogli di lamiera sottili o lastre di vetro.

La ventosa presenta un trattamento vulcanizzato che la rende più resistente alle abrasioni e all'usura ma soprattutto alle forze di trazione nonché permette alla gomma di degradarsi con meno facilità rendendola più resistente ad agenti ambientali aggressivi migliorandone la durata di utilizzo.

La configurazione a multi-soffiato rende la ventosa adatta a differenti superfici anche non regolari, con errori di planarità o inclinate, permettendone l'impiego in differenti applicazioni tra cui la movimentazione di pannelli di legno (truciolare o pressato) o laminati plastici.

La corsa effettiva del soffiato è pari a 24 mm.

Vedi Dati tecnici ventose (a pag. -).

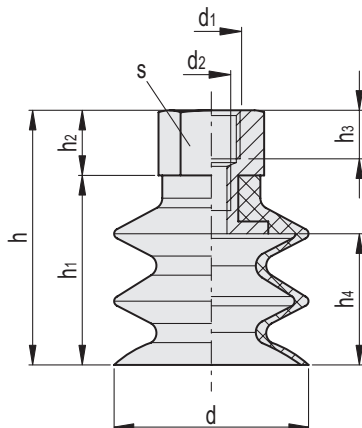
**VVP-50-T-A**

Codice	Descrizione	d	d1	d2	h	h1	h2	h3	h4	s	F* [Kg]	Volume # [cm3]	⚖
VV.60504	VVP-50-G1/4-T-A	50	G1/4	M8	72	55	17	13	38	20	4.90	41.6	50

VVP-50-T-N

Codice	Descrizione	d	d1	d2	h	h1	h2	h3	h4	s	F* [Kg]	Volume # [cm3]	⚖
VV.60505	VVP-50-G1/4-T-N	50	G1/4	M8	72	55	17	13	38	20	4.90	41.6	50

VVP-50-T-S

Codice	Descrizione	d	d1	d2	h	h1	h2	h3	h4	s	F* [Kg]	Volume # [cm3]	⚖
VV.60506	VVP-50-G1/4-T-S	50	G1/4	M8	72	55	17	13	38	20	4.90	41.6	50

* La forza delle ventose indicata in tabella, rappresenta 1/3 del valore della forza teorica calcolata ad un grado di vuoto di -75 KPa ed un coefficiente di sicurezza 3.
Indica il volume geometrico interno della ventosa e rappresenta il volume da aggiungere all'intero circuito di distribuzione per il calcolo del tempo di evacuazione, soprattutto in caso si utilizzino molteplici ventose.