



1

MATERIALE

Ventosa in gomma antiolio (NBR), naturale (NR) o siliconica (VMQ).
Supporto in alluminio anodizzato.



2

ESECUZIONI STANDARD

- **VVM-30-A:** gomma antiolio, senza supporto.
- **VVM-30-N:** gomma naturale, senza supporto.
- **VVM-30-S:** gomma siliconica, senza supporto.
- **VVM-30-T-A:** gomma antiolio, con supporto.
- **VVM-30-T-N:** gomma naturale, con supporto.
- **VVM-30-T-S:** gomma siliconica, con supporto.



3



4



5

CARATTERISTICHE E APPLICAZIONI

Sono specificatamente indicate nel settore del packaging alimentare in particolare per la movimentazione di prodotti da forno o prodotti dolciari, in cui la forma a multi-soffietto si adatta perfettamente alla movimentazione prodotti confezionati anche fragili. (es. biscotti, pane, snack).

L'adattabilità a differenti superfici anche non regolari, con errori di planarità o inclinate permette a queste ventose di essere impiegate anche in settori differenti in cui la forma multi-soffietto risulta particolarmente efficace.

La corsa effettiva del soffietto è pari a 22 mm.

Vedi Dati tecnici ventose (a pag. -).



6



7



8



9



10



11



12



13



14



15



16



17



18



19



20



21



22



23



24



25



26



27



28



29

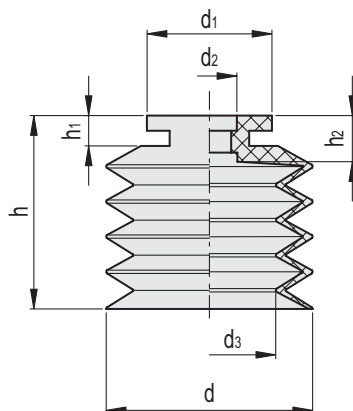

30

**VVM-30-A**

Codice	Descrizione	d	d1	d2	d3	h	h1	h2	F* [Kg]	Volume # [cm3]	⚖
VV.57007	VVM-30-A	30	20	6.5	21	32	5	7	1.76	11.4	6

VVM-30-N

Codice	Descrizione	d	d1	d2	d3	h	h1	h2	F* [Kg]	Volume # [cm3]	⚖
VV.57008	VVM-30-N	30	20	6.5	21	32	5	7	1.76	11.4	6

VVM-30-S

Codice	Descrizione	d	d1	d2	d3	h	h1	h2	F* [Kg]	Volume # [cm3]	⚖
VV.57009	VVM-30-S	30	20	6.5	21	32	5	7	1.76	11.4	6

* La forza delle ventose indicata in tabella, rappresenta 1/3 del valore della forza teorica calcolata ad un grado di vuoto di -75 KPa ed un coefficiente di sicurezza 3.
Indica il volume geometrico interno della ventosa e rappresenta il volume da aggiungere all'intero circuito di distribuzione per il calcolo del tempo di evacuazione, soprattutto in caso si utilizzino molteplici ventose.

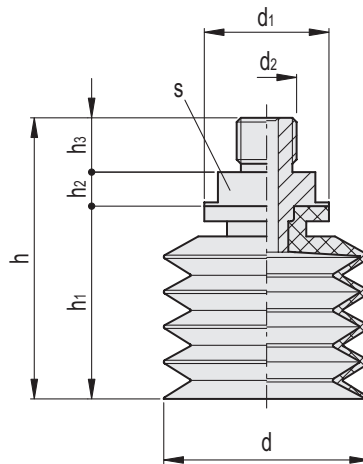

VVM-30-T-A

Codice	Descrizione	d	d1	d2	h	h1	h2	h3	s	F* [Kg]	Volume # [cm3]	⚖️
VV.57010	VVM-30-G1/4-T-A	30	20	G1/4	51.5	32	7.5	12	17	1.76	11.4	16

VVM-30-T-N

Codice	Descrizione	d	d1	d2	h	h1	h2	h3	s	F* [Kg]	Volume # [cm3]	⚖️
VV.57011	VVM-30-G1/4-T-N	30	20	G1/4	51.5	32	7.5	12	17	1.76	11.4	16

VVM-30-T-S

Codice	Descrizione	d	d1	d2	h	h1	h2	h3	s	F* [Kg]	Volume # [cm3]	⚖️
VV.57012	VVM-30-G1/4-T-S	30	20	G1/4	51.5	32	7.5	12	17	1.76	11.4	16

* La forza delle ventose indicata in tabella, rappresenta 1/3 del valore della forza teorica calcolata ad un grado di vuoto di -75 KPa ed un coefficiente di sicurezza 3.
 # Indica il volume geometrico interno della ventosa e rappresenta il volume da aggiungere all'intero circuito di distribuzione per il calcolo del tempo di evacuazione, soprattutto in caso si utilizzino molteplici ventose.