



1

ESECUZIONI STANDARD

Acciaio INOX AISI 316L, finitura mat da sabbiatura.

- VMT-A4: senza foro.
- VMT-A4 (dH7): con foro cieco liscio.
- VMT-A4 (d): con foro cieco filettato.
- VMT-A4-FP: con foro passante filettato.



2



3

CARATTERISTICHE E APPLICAZIONI

La forma a tre lobi e quindi con ampi incavi, risulta particolarmente ergonomica, assicurando una presa efficace anche con guanti da lavoro.

Il design privo di cavità posteriori, impedisce il deposito di residui antigienici assicurando la massima pulibilità.

Particolarmente adatto per applicazioni su macchine ed attrezzature soggette a frequenti interventi di pulizia con getti d'acqua o di vapore.



4



5



6

ESECUZIONI SPECIALI A RICHIESTA

Finitura lucida.



7



8



9



10



11



12



13



14



15



16



17



18

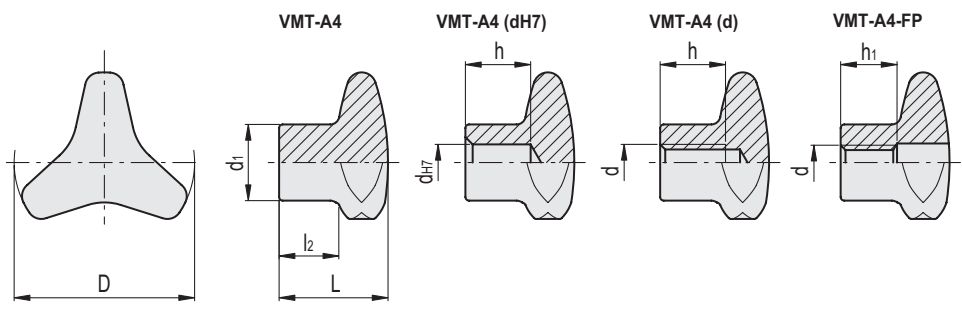

VMT-A4



Codice	Descrizione	D	L	d1	l2	⚖
169451	VMT.25-A4	25	16	12	8	21
169461	VMT.32-A4	32	21	15	11	44
169595	VMT.40-A4	40	26	18	15	96
169605	VMT.50-A4	50	30	21	17	128
169615	VMT.60-A4	60	35	25	18	219

VMT-A4 (dH7)



Codice	Descrizione	D	dH7	L	d1	l2	h	⚖
169596	VMT.40-A4-8	40	8	26	18	15	15	70
169606	VMT.50-A4-10	50	10	30	21	17	18	114
169616	VMT.60-A4-12	60	12	35	25	18	22	195

VMT-A4 (d)

Codice	Descrizione	D	d	L	d1	l2	h	⚖
169452	VMT.25-A4-M5	25	M5	16	12	8	10	20
169462	VMT.32-A4-M6	32	M6	21	15	11	12	41
169597	VMT.40-A4-M6	40	M6	26	18	15	12	65
169598	VMT.40-A4-M8	40	M8	26	18	15	15	70
169607	VMT.50-A4-M8	50	M8	30	21	17	15	109
169608	VMT.50-A4-M10	50	M10	30	21	17	18	138
169617	VMT.60-A4-M10	60	M10	35	25	18	18	190
169618	VMT.60-A4-M12	60	M12	35	25	18	22	232

VMT-A4-FP

Codice	Descrizione	D	d	L	d1	l2	h1	⚖
169453	VMT.25-A4-FP-M5	25	M5	16	12	8	11	19
169463	VMT.32-A4-FP-M6	32	M6	21	15	11	13	40
169619	VMT.40-A4-FP-M6	40	M6	26	18	15	13	60
169620	VMT.40-A4-FP-M8	40	M8	26	18	15	13	67
169621	VMT.50-A4-FP-M8	50	M8	30	21	17	16	117
169622	VMT.50-A4-FP-M10	50	M10	30	21	17	16	111
169623	VMT.60-A4-FP-M10	60	M10	35	25	18	20	197
169624	VMT.60-A4-FP-M12	60	M12	35	25	18	20	188