

TSLA. | Testate sostegno laterale

Tecnopolimero



MATERIALE

Tecnopolimero a base poliammidica (PA) rinforzato fibra vetro, colore nero, finitura mat.

ESECUZIONI STANDARD

- **TSLA-A:** vite M10, dado e rondella in acciaio zincato.
- **TSLA-SST:** vite M10, dado e rondella in acciaio INOX AISI 304.

CARATTERISTICHE

Coppia massima per il serraggio delle viti 35 Nm.

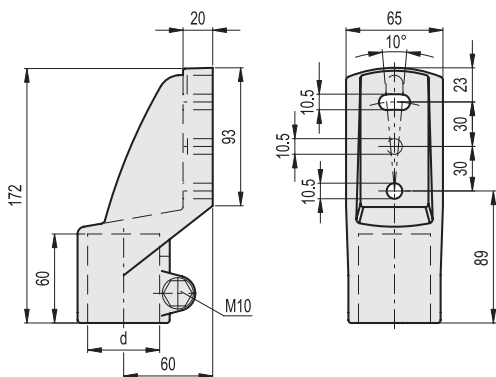

TSLA-A

Codice	Descrizione	d Tubo (mm)	d Tubo (GAS)	
419648	TSLA-48-A	48.3	1"1/2	320

TSLA-SST

Codice	Descrizione	d Tubo (mm)	d Tubo (GAS)	
419649	TSLA-48-SST	48.3	1"1/2	320



TSLB. | Testate sostegno laterale

Tecnopolimero



MATERIALE

Tecnopolimero a base poliammidica (PA) rinforzato fibra vetro, colore nero, finitura mat.

ESECUZIONI STANDARD

- **TSLB-A:** vite M10, dado e rondella in acciaio zincato.
- **TSLB-SST:** vite M10, dado e rondella in acciaio INOX AISI 304.

CARATTERISTICHE

Coppia massima per il serraggio delle viti 35 Nm.

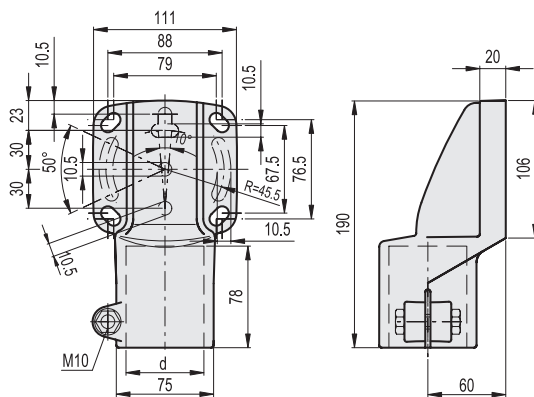

TSLB-A

Codice	Descrizione	d Tubo (mm)	d Tubo (GAS)	
419794	TSLB-42-A	42.4	1"1/4	435
419792	TSLB-48-A	48.3	1"1/2	430
419790	TSLB-60-A	60.3	2"	425
419796	TSLB-45x45-A	45	-	430

TSLB-SST

Codice	Descrizione	d Tubo (mm)	d Tubo (GAS)	
419795	TSLB-42-SST	42.4	1"1/4	435
419793	TSLB-48-SST	48.3	1"1/2	430
419791	TSLB-60-SST	60.3	2"	425
419797	TSLB-45x45-SST	45	-	430

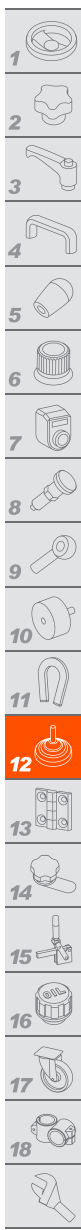

Elementi di livellamento e sostegno

1261