

MATERIALE

Tecnopolimero a base poliammidica (PA), rinforzato fibra vetro, colore grigio RAL 7035 (C3).

ESECUZIONI STANDARD

- **CGT-HR**: filettatura metrica.
- **CGT-HR-PG**: filettatura PG.

CARATTERISTICHE E APPLICAZIONI

Vengono utilizzati per installare un pressacavo in un foro di montaggio dell' apparecchiatura elettrica non corrispondente alla misura del filetto del pressacavo stesso, garantendo la protezione meccanica e il grado di tenuta. Per il fissaggio delle riduzioni utilizzare la ghiera di ritegno CGT-NTC.

ACCESSORIO

- CGT: pressacavi.
- CGT-NTC: ghiera di ritegno.

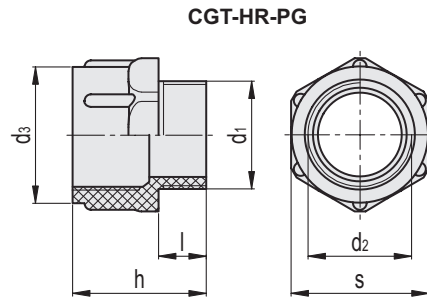
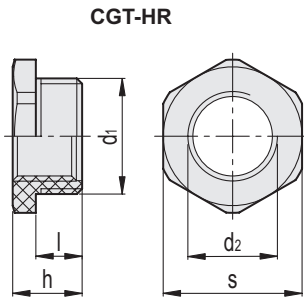
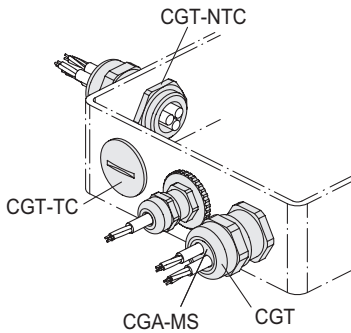

CGT-HR

| Codice | Descrizione | d1 | d2 | h | l | s | ⚖ |
|-----------|-------------------|------------|------------|----|----|----|----|
| 560201-C3 | CGT-HR-M16-M12-C3 | M 16 x 1.5 | M 12 x 1.5 | 12 | 8 | 24 | 3 |
| 560203-C3 | CGT-HR-M20-M16-C3 | M 20 x 1.5 | M 16 x 1.5 | 12 | 8 | 24 | 4 |
| 560205-C3 | CGT-HR-M25-M20-C3 | M 25 x 1.5 | M 20 x 1.5 | 14 | 8 | 32 | 7 |
| 560207-C3 | CGT-HR-M32-M25-C3 | M 32 x 1.5 | M 25 x 1.5 | 16 | 10 | 36 | 9 |
| 560209-C3 | CGT-HR-M40-M32-C3 | M 40 x 1.5 | M 32 x 1.5 | 19 | 12 | 46 | 16 |
| 560211-C3 | CGT-HR-M50-M40-C3 | M 50 x 1.5 | M 40 x 1.5 | 21 | 14 | 55 | 24 |
| 560213-C3 | CGT-HR-M63-M50-C3 | M 63 x 1.5 | M 50 x 1.5 | 22 | 15 | 65 | 34 |

CGT-HR-PG

| Codice | Descrizione | d1 | d2 | h | l | s | ⚖ |
|-----------|-----------------------|---------|---------|------|----|----|----|
| 560215-C3 | CGT-HR-PG9-PG7-C3 | PG 9 | PG 7 | 20.5 | 8 | 19 | 5 |
| 560217-C3 | CGT-HR-PG11-PG9-C3 | PG 11 | PG 9 | 22.5 | 8 | 22 | 6 |
| 560219-C3 | CGT-HR-PG13,5-PG11-C3 | PG 13.5 | PG 11 | 24 | 9 | 24 | 6 |
| 560221-C3 | CGT-HR-PG16-PG13,5-C3 | PG 16 | PG 13.5 | 28 | 10 | 27 | 7 |
| 560223-C3 | CGT-HR-PG21-PG16-C3 | PG 21 | PG 16 | 16 | 11 | 32 | 8 |
| 560225-C3 | CGT-HR-PG29-PG21-C3 | PG 29 | PG 21 | 17 | 11 | 40 | 14 |
| 560227-C3 | CGT-HR-PG36-PG29-C3 | PG 36 | PG 29 | 24 | 18 | 50 | 14 |
| 560229-C3 | CGT-HR-PG42-PG36-C3 | PG 42 | PG 36 | 24 | 18 | 55 | 19 |
| 560231-C3 | CGT-HR-PG48-PG42-C3 | PG 48 | PG 42 | 6 | 17 | 60 | 19 |

Elementi meccanici