

MATERIAL

Vacuum cup in oil-proof rubber (NBR), natural (NR), or silicone (VMQ). Support in anodised aluminium.

STANDARD EXECUTIONS

- **VVK-A**: oil-proof rubber, without support.
- **VVK-N**: natural rubber, without support.
- **VVK-S**: silicone rubber, without support.
- **VVK-T-A**: oil-proof rubber, with support.
- **VVK-T-N**: natural rubber, with support.
- **VVK-T-S**: silicone rubber, with support.

FEATURES

They have a particularly flexible lip that enables them to adapt to flat (smooth or rough), concave and convex surfaces, even very thin ones. The presence of the grooves on the surface of the vacuum cup allows for superior grip and a more effective grip on the object to be manipulated.

APPLICATIONS

They are specifically used in the ceramic sector in particular for handling tiles with smooth or shaped surfaces; however, they can also be used with different surfaces such as glass, marble and concrete. See Technical Data for vacuum cups (on page -).

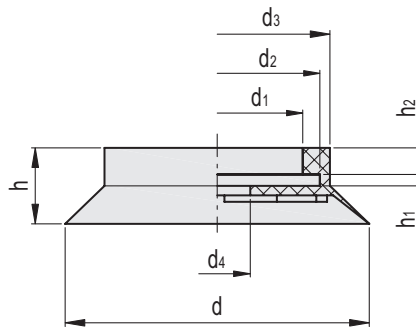

VVK-A

Code	Description	d	d1	d2	d3	d4	h	h1	h2	F* [Kg]	Volume # [cm3]	⚖️
VV.55001	VVK-80-A	80	45	54	58	17	20	3	7	12.6	27	26

VVK-N

Code	Description	d	d1	d2	d3	d4	h	h1	h2	F* [Kg]	Volume # [cm3]	⚖️
VV.55002	VVK-80-N	80	45	54	58	17	20	3	7	12.6	27	26

VVK-S

Code	Description	d	d1	d2	d3	d4	h	h1	h2	F* [Kg]	Volume # [cm3]	⚖️
VV.55003	VVK-80-S	80	45	54	58	17	20	3	7	12.6	27	26

* The force of the vacuum cups indicated in the table represents 1/3 of the value of the theoretical force calculated at a vacuum level of -75 KPa and a safety coefficient of 3.

Indicates the internal geometric volume of the vacuum cup and represents the volume to be added to the entire distribution circuit for the calculation of the evacuation time, especially if multiple vacuum cups are used.

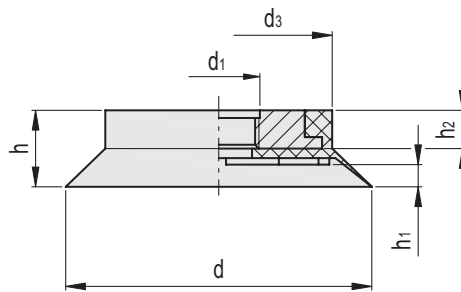

VVK-T-A

Code	Description	d	d1	d3	h	h1	h2	F* [Kg]	Volume # [cm3]	⚖️
VV.55004	VVK-80-M12-T-A	80	M12	58	20	6	10	12.6	27	71
VV.55007	VVK-80-G1/4-T-A	80	G1/4	58	20	6	10	12.6	27	67
VV.55010	VVK-80-G3/8-T-A	80	G3/8	58	20	6	10	12.6	27	67
VV.55013	VVK-80-G1/2-T-A	80	G1/2	58	20	6	10	12.6	27	67

VVK-T-N

Code	Description	d	d1	d3	h	h1	h2	F* [Kg]	Volume # [cm3]	⚖️
VV.55005	VVK-80-M12-T-N	80	M12	58	20	6	10	12.6	27	71
VV.55008	VVK-80-G1/4-T-N	80	G1/4	58	20	6	10	12.6	27	67
VV.55011	VVK-80-G3/8-T-N	80	G3/8	58	20	6	10	12.6	27	67
VV.55014	VVK-80-G1/2-T-N	80	G1/2	58	20	6	10	12.6	27	67

VVK-T-S

Code	Description	d	d1	d3	h	h1	h2	F* [Kg]	Volume # [cm3]	⚖️
VV.55006	VVK-80-M12-T-S	80	M12	58	20	6	10	12.6	27	71
VV.55009	VVK-80-G1/4-T-S	80	G1/4	58	20	6	10	12.6	27	67
VV.55012	VVK-80-G3/8-T-S	80	G3/8	58	20	6	10	12.6	27	67
VV.55015	VVK-80-G1/2-T-S	80	G1/2	58	20	6	10	12.6	27	67

* The force of the vacuum cups indicated in the table represents 1/3 of the value of the theoretical force calculated at a vacuum level of -75 KPa and a safety coefficient of 3.

Indicates the internal geometric volume of the vacuum cup and represents the volume to be added to the entire distribution circuit for the calculation of the evacuation time, especially if multiple vacuum cups are used.

