

- 1
- 2
- 3
- 4
- 5
- 6
- 7
- 8
- 9
- 10
- 11
- 12
- 13
- 14
- 15
- 16
- 17
- 18

MATERIAL

High-strength, reinforced phenolic based (PF) Duroplast, black colour, glossy finish.

STANDARD EXECUTIONS

Black-oxide steel hub, uncovered front end, H7 reamed hole.

H9 reamed hole for executions with keyway:

- **VR.FP-A**: without handle.
- **VR.FP+I-A**: with revolving handle I.301+x (see page 405) in Duroplast.
- **VR.FP+IR-A**: with fold-away handle IR.302 (see page 411) in Duroplast.
- **K**: index for executions with hole and keyway in compliance with DIN 6885/1 (see page A-16), tolerance P9 i.e.: 77111-10-K VR.100 FP-A10-K

Black-oxide steel hub, not drilled, uncovered front end in order to make holes different from the standard:

- **VR.FP**: without handle.
- **VR.FP+I**: with revolving handle I.301+x (see page 405) in Duroplast.
- **VR.FP+IR**: with fold-away handle IR.302 (see page 411) in Duroplast.

ACCESSORIES ON REQUEST

Axial retaining washer GN 184 (see page 677).



ELESA Original design

VR.FP-A

VR.FP+I-A

VR.FP+IR-A

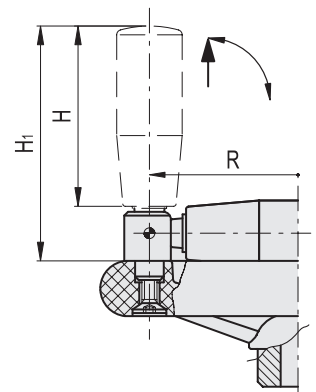
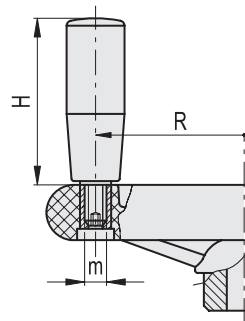
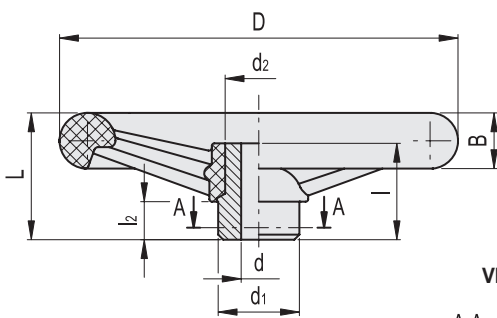

VR.FP...A-K

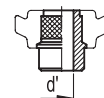
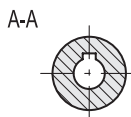

d' Max diameter permissible

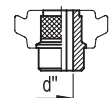

d'' Max diameter for hole with keyway



VR.FP-A

Code	Description	D	dH7	L	B	d1	d2	l	l2	d'	d''	t	b	C# [Nm]	L# [J]	⚖️
77111-10	VR.100 FP-A10	98	10	40	14	24	20	36	12	16	13	15.3	5	67	5	165
77111-12	VR.100 FP-A12	98	12	40	14	24	20	36	12	16	13	15.3	5	67	5	160
77211-12	VR.125 FP-A12	124	12	45	18	24	20	36	12	16	13	15.3	5	120	8	230
77211-14	VR.125 FP-A14	124	14	45	18	24	20	36	12	16	13	15.3	5	120	8	225
77311-14	VR.140 FP-A14	139	14	47	20	32	24	38	15	20	16	18.3	5	165	12	375
77311-16	VR.140 FP-A16	139	16	47	20	32	24	38	15	20	16	18.3	5	165	12	370
77411-14	VR.160 FP-A14	157	14	50	22	32	24	38	15	20	16	18.3	5	165	12	440
77411-16	VR.160 FP-A16	157	16	50	22	32	24	38	15	20	16	18.3	5	165	12	435
77511-16	VR.180 FP-A16	180	16	56	24	40	31	43	15	26	22	24.8	6	280	15	680
77511-18	VR.180 FP-A18	180	18	56	24	40	31	43	15	26	22	24.8	6	280	15	670
77611-18	VR.200 FP-A18	198	18	57	26	40	30.5	43	15	26	22	24.8	6	300	16	730
77611-20	VR.200 FP-A20	198	20	57	26	40	30.5	43	15	26	22	24.8	6	300	16	720
77711-22	VR.250 FP-A22	247	22	66	30	49	38	44	15	34	27	30.3	8	405	19	1205
77711-24	VR.250 FP-A24	247	24	66	30	49	38	44	15	34	27	30.3	8	405	19	1200
77811-26	VR.300 FP-A26	288	26	78	32	58	47	56	18	42	34	37.3	10	800	33	2030

VR.FP+I-A

Code	Description	D	dH7	L	B	d1	d2	l	l2	H	m	R	d'	d''	t	b	C# [Nm]	L# [J]	⚖️
77121-10	VR.100 FP+I-A10	98	10	40	14	24	20	36	12	40	M6	37	16	13	15.3	5	67	5	195
77121-12	VR.100 FP+I-A12	98	12	40	14	24	20	36	12	40	M6	37	16	13	15.3	5	67	5	190
77221-12	VR.125 FP+I-A12	124	12	45	18	24	20	36	12	50	M8	47	16	13	15.3	5	120	8	290
77221-14	VR.125 FP+I-A14	124	14	45	18	24	20	36	12	50	M8	47	16	13	15.3	5	120	8	285
77321-14	VR.140 FP+I-A14	139	14	47	20	32	24	38	15	65	M8	53	20	16	18.3	5	165	12	460
77321-16	VR.140 FP+I-A16	139	16	47	20	32	24	38	15	65	M8	53	20	16	18.3	5	165	12	455
77421-14	VR.160 FP+I-A14	157	14	50	22	32	24	38	15	65	M8	59	20	16	18.3	5	165	12	525
77421-16	VR.160 FP+I-A16	157	16	50	22	32	24	38	15	65	M8	59	20	16	18.3	5	165	12	520
77521-16	VR.180 FP+I-A16	180	16	56	24	40	31	43	15	80	M10	68	26	22	24.8	6	280	15	810
77521-18	VR.180 FP+I-A18	180	18	56	24	40	31	43	15	80	M10	68	26	22	24.8	6	280	15	800
77621-18	VR.200 FP+I-A18	198	18	57	26	40	30.5	43	15	80	M10	76	26	22	24.8	6	300	16	855
77621-20	VR.200 FP+I-A20	198	20	57	26	40	30.5	43	15	80	M10	76	26	22	24.8	6	300	16	845
77721-22	VR.250 FP+I-A22	247	22	66	30	49	38	44	15	90	M10	98	34	27	30.3	8	405	19	1390
77721-24	VR.250 FP+I-A24	247	24	66	30	49	38	44	15	90	M10	98	34	27	30.3	8	405	19	1380
77821-26	VR.300 FP+I-A26	288	26	78	32	58	47	56	18	100	M12	113	42	34	37.3	10	800	33	2300

VR.FP+IR-A

Code	Description	D	dH7	L	B	d1	d2	l	l2	H	H1	R	d'	d''	t	b	C# [Nm]	L# [J]	⚖️
77531-16	VR.180 FP+IR-A16	180	16	56	24	40	31	43	15	80	100	68	26	22	24.8	6	280	15	825
77531-18	VR.180 FP+IR-A18	180	18	56	24	40	31	43	15	80	100	68	26	22	24.8	6	280	15	820
77631-18	VR.200 FP+IR-A18	198	18	57	26	40	30.5	43	15	80	100	76	26	22	24.8	6	300	16	850
77631-20	VR.200 FP+IR-A20	198	20	57	26	40	30.5	43	15	80	100	76	26	22	24.8	6	300	16	840
77731-22	VR.250 FP+IR-A22	247	22	66	30	49	38	44	15	90	113	98	34	27	30.3	8	405	19	1435
77731-24	VR.250 FP+IR-A24	247	24	66	30	49	38	44	15	90	113	98	34	27	30.3	8	405	19	1425
77831-26	VR.300 FP+IR-A26	288	26	78	32	58	47	56	18	90	113	113	42	34	37.3	10	800	33	2345

* To order the execution with hole and keyway add the index -K after the code and description (i.e. 77111-10-K VR.100 FP-A10-K).

For maximum torque (C) and impact strength (L) see Technical data on page A-3.

- 1
- 2
- 3
- 4
- 5
- 6
- 7
- 8
- 9
- 10
- 11
- 12
- 13
- 14
- 15
- 16
- 17
- 18

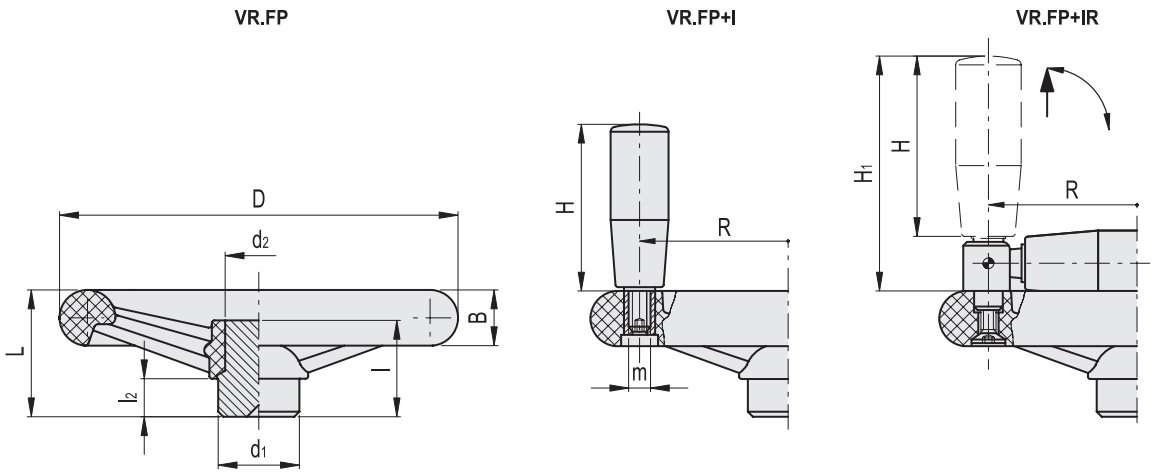

VR.FP

Code	Description	D	L	B	d1	d2	l	l2	d'	d''	t	b	C# [Nm]	L# [J]	⚖
77111	VR.100 FP	98	40	14	24	20	36	12	16	13	15.3	5	67	5	175
77211	VR.125 FP	124	45	18	24	20	36	12	16	13	15.3	5	120	8	240
77311	VR.140 FP	139	47	20	32	24	38	15	20	16	18.3	5	165	12	390
77411	VR.160 FP	157	50	22	32	24	38	15	20	16	18.3	5	165	12	455
77511	VR.180 FP	180	56	24	40	31	43	15	26	22	24.8	6	280	15	700
77611	VR.200 FP	198	57	26	40	30.5	43	15	26	22	24.8	6	300	16	750
77711	VR.250 FP	247	66	30	49	38	44	15	34	27	30.3	8	405	19	1235
77811	VR.300 FP	288	78	32	58	47	56	18	42	34	37.3	10	800	33	2060
77901	VR.375 FP	375	108	40	58	58	77	26	45	40	43.3	12	1450	70	3900

VR.FP+I

Code	Description	D	L	B	d1	d2	l	l2	H	m	R	d'	d''	t	b	C# [Nm]	L# [J]	⚖
77121	VR.100 FP+I	98	40	14	24	20	36	12	40	M6	37	16	13	15.3	5	67	5	205
77221	VR.125 FP+I	124	45	18	24	20	36	12	50	M8	47	16	13	15.3	5	120	8	300
77321	VR.140 FP+I	139	47	20	32	24	38	15	65	M8	53	20	16	18.3	5	165	12	475
77421	VR.160 FP+I	157	50	22	32	24	38	15	65	M8	59	20	16	18.3	5	165	12	540
77521	VR.180 FP+I	180	56	24	40	31	43	15	80	M10	68	26	22	24.8	6	280	15	830
77621	VR.200 FP+I	198	57	26	40	30.5	43	15	80	M10	76	26	22	24.8	6	300	16	880
77721	VR.250 FP+I	247	66	30	49	38	44	15	90	M10	98	34	27	30.3	8	405	19	1420
77821	VR.300 FP+I	288	78	32	58	47	56	18	100	M12	113	42	34	37.3	10	800	33	2335
77911	VR.375 FP+I	375	108	40	58	58	77	26	100	M12	160	45	40	43.3	12	1450	70	4170

VR.FP+IR

Code	Description	D	L	B	d1	d2	l	l2	H	H1	R	d'	d''	t	b	C# [Nm]	L# [J]	⚖
77531	VR.180 FP+IR	180	56	24	40	31	43	15	80	100	68	26	22	24.8	6	280	15	840
77631	VR.200 FP+IR	198	57	26	40	30.5	43	15	80	100	76	26	22	24.8	6	300	16	875
77731	VR.250 FP+IR	247	66	30	49	38	44	15	90	113	98	34	27	30.3	8	405	19	1465
77831	VR.300 FP+IR	288	78	32	58	47	56	18	90	113	113	42	34	37.3	10	800	33	2380
77921	VR.375 FP+IR	375	108	40	58	58	77	26	90	113	160	45	40	43.3	12	1450	70	4250

Handwheels and crank handles