

- 1 COVER
- 2 FITTING
- 3 PACKING RINGS
- 4 AIR FILTER
- 5 FLAT DIPSTICK
- 6 MAXIMUM CONTINUOUS WORKING TEMPERATURE
- 7 FEATURES AND APPLICATIONS
- 8 TECHNICAL DATA
- 9
- 10
- 11
- 12
- 13
- 14
- 15
- 16
- 17
- 18
- 19

COVER

Polyamide based (PA) technopolymer, black colour, semi-matte finish, "fill" symbol.

FITTING

Polyamide based (PA) technopolymer, black colour, semi-matte finish.

PACKING RINGS

Two NBR synthetic rubber O-rings.

AIR FILTER

"tech-foam" air filter in polyurethane foam mesh (polyester base), with air filtration 40 µm.

FLAT DIPSTICK

Flat section phosphatised steel.

On request and for sufficient quantities dipstick can be supplied in different lengths and/or complete with MAX-MIN level lines.

MAXIMUM CONTINUOUS WORKING TEMPERATURE

80°C.

FEATURES AND APPLICATIONS

Push-fit avoids the need to screw/unscrew, allowing for quick installation. See Fig.1 for the dimensions of the assembly hole. Chamfer hole 1x45° the outside surface to make assembly easier.

The product is designed to vent slight overpressures; the pressure inside the tank must not exceed 200 mb, under optimum conditions of cleanliness of the assembly hole and at room temperature.

The TP-SP+a breather caps are made with a special internal geometry (Elesa patent) that prevents the leakage of fluids through a linear labyrinth (splash guard effect) and promotes condensation of the outgoing vapours.

TECHNICAL DATA

Air flow rate for each model can be determined from the graph calculating the difference between the pressure inside and outside the reservoir.

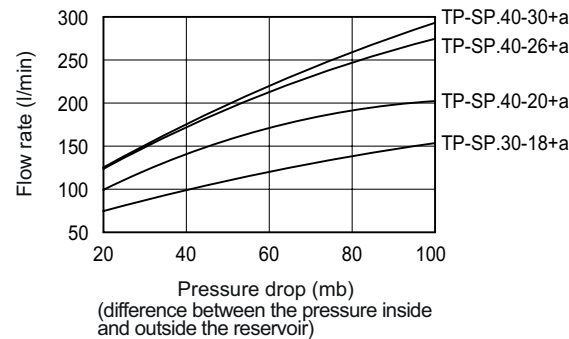

ELESA Original design

Operating layout

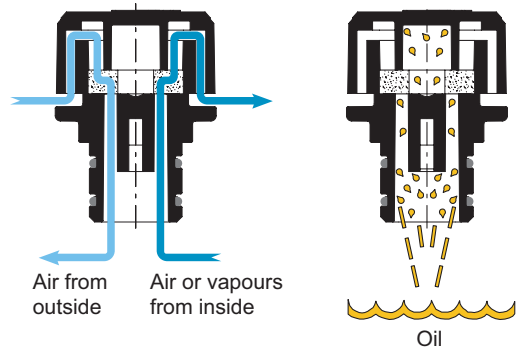
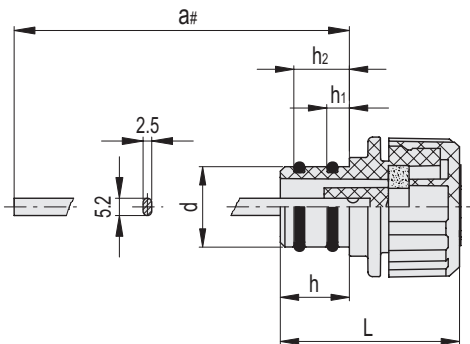
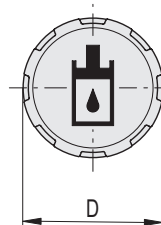
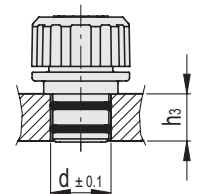

Fig.1

| Description | d ± 0.1 | h3 min |
|-------------|---------|--------|
| TP-SP.30-18 | 18 | 15 |
| TP-SP.40-20 | 20 | 20 |
| TP-SP.40-26 | 26 | 20 |
| TP-SP.40-30 | 30 | 20 |



| Code | Description | D | d | a# | L | h | h1 | h2 | ΔΔ |
|-------|-----------------|------|----|-----|------|----|-----|----|----|
| 60251 | TP-SP.30-18+F+a | 30.5 | 18 | 194 | 39.5 | 15 | 4.5 | 12 | 38 |
| 60261 | TP-SP.40-20+F+a | 42.5 | 20 | 196 | 48.5 | 20 | 6.5 | 16 | 45 |
| 60271 | TP-SP.40-26+F+a | 42.5 | 26 | 196 | 48.5 | 20 | 6.5 | 16 | 47 |
| 60281 | TP-SP.40-30+F+a | 42.5 | 30 | 196 | 48.5 | 20 | 6.5 | 16 | 48 |

You can choose lengths other than the standard option and/or add MAX-MIN level markings. To request customization, select an item and follow the wizard on the web.