

1	COVERING
2	WHEEL CENTRE BODY
3	ROLLING ACTION
4	FIXED PLATE BRACKET
5	TURNING PLATE BRACKET
6	TURNING PLATE BRACKET
7	TURNING PLATE BRACKET
8	TURNING PLATE BRACKET
9	TURNING PLATE BRACKET
10	TURNING PLATE BRACKET
11	BRAKE
12	BRAKE
13	BRAKE
14	BRAKE
15	STANDARD EXECUTIONS
16	STANDARD EXECUTIONS
17	APPLICATIONS
18	APPLICATIONS
19	APPLICATIONS

**COVERING**

Mould-on polyurethane, hardness 92 Shore A.

**WHEEL CENTRE BODY**

Pressure die-cast aluminium.

**ROLLING ACTION**

Hub with ball bearings.  
Ideal solution for heavy loads and continuous moving.

**FIXED PLATE BRACKET**

Zinc-plated steel sheet, the bracket is designed to withstand loads up to 3000N.

**TURNING PLATE BRACKET**

Zinc-plated steel sheet, the bracket is designed to withstand loads up to 3000N.

The presence of a double ball race and direct contact between the plate and the ball race ring with built-in pin ensure excellent manoeuvrability. Does not require maintenance.

It consists of (see Fig.1):

1. fitting plate: yellow zinc-plated steel sheet;
2. fork: yellow zinc-plated steel sheet;
3. ball race ring: yellow zinc-plated steel sheet;
4. central pin: class 8.8 steel screw and steel nut;
5. rotation system: dual grease-lubricated ball race;
6. dust seal: RAL 7015 dark grey technopolymer.

**BRAKE**

Total brake that locks the wheel and bracket rotation.  
The optimised dimensions and the retractible pedal ensure minimal space occupied and maximum actuation ease.  
Hardened carbon steel spring.

The trolley must be turned to use the device.

The brake is simple and effective to use: it is actuated and released by a simple action from the top downward at the tip of two separate pedals, thus ensuring the utmost manoeuvring comfort.

**STANDARD EXECUTIONS**

- **PSL-N**: fixed plate bracket, without brake.
- **SSL-N**: turning plate bracket, without brake.
- **SSF-N**: turning plate bracket, with brake.

**FSL-N**: turning plate bracket and centre pass-through hole, without brake.

**FSF-N**: turning plate bracket and centre pass-through hole, with brake.

**APPLICATIONS**

Excellent rolling resistance and elasticity features, high wear and tearing resistance.

For further information see wheel technical data sheet RE.F5 (see page 1251).

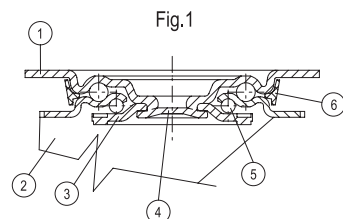

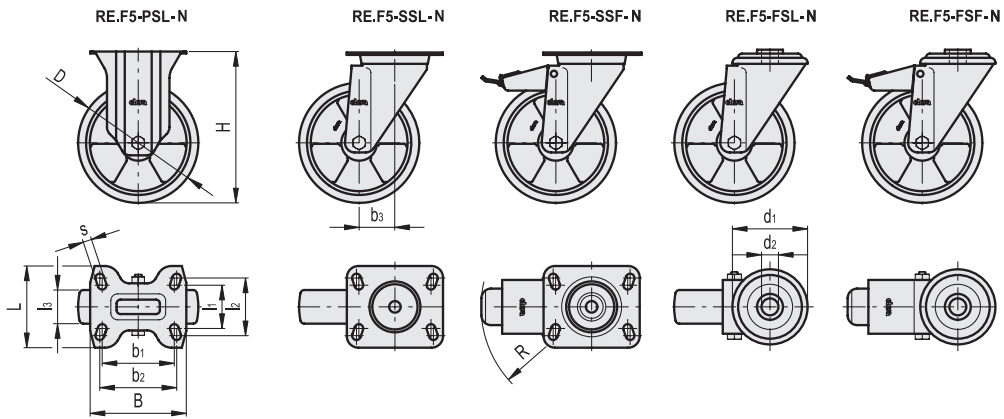

**RE.F5-PSL-N**

Code	Description	D	I1	I2	I3	H	B	L	s	b1	b2	Rolling resistance# [N]	Dynamic carrying capacity# [N]	⚖️
451651	RE.F5-080-PSL-N	80	45	60	25	107	100	85	9	75	80	1500	2000	520
451656	RE.F5-100-PSL-N	100	45	60	30	128	100	85	9	75	80	2250	2000	690
451661	RE.F5-125-PSL-N	125	45	60	35	156	100	85	9	75	80	2800	2200	890
451666	RE.F5-150-PSL-N	150	73	87	40	194	140	110	11	105	105	3300	3000	2040
451671	RE.F5-200-PSL-N	200	73	87	50	240	140	110	11	105	105	3600	3000	2760

**RE.F5-SSL-N**

Code	Description	D	I1	I2	I3	H	B	L	s	b1	b2	b3	Rolling resistance# [N]	Dynamic carrying capacity# [N]	⚖️
451551	RE.F5-080-SSL-N	80	45	60	25	107	100	85	9	75	80	40	1500	2000	720
451556	RE.F5-100-SSL-N	100	45	60	30	128	100	85	9	75	80	35	2250	2000	940
451561	RE.F5-125-SSL-N	125	45	60	35	156	100	85	9	75	80	37	2800	2200	1140
451565	RE.F5-150-SSL-N	150	73	87	40	194	140	110	11	105	105	56	3300	3000	2340
451571	RE.F5-200-SSL-N	200	73	87	50	240	140	110	11	105	105	56	3600	3000	3050

**RE.F5-SSF-N**

Code	Description	D	I1	I2	I3	H	B	L	s	b1	b2	b3	R	Rolling resistance# [N]	Dynamic carrying capacity# [N]	⚖️
451601	RE.F5-080-SSF-N	80	45	60	25	107	100	85	9	75	80	40	120	1500	2000	806
451606	RE.F5-100-SSF-N	100	45	60	30	128	100	85	9	75	80	35	120	2250	2000	1080
451611	RE.F5-125-SSF-N	125	45	60	35	156	100	85	9	75	80	37	120	2800	2200	1280
451615	RE.F5-150-SSF-N	150	73	87	40	194	140	110	11	105	105	56	156	3300	3000	2630
451621	RE.F5-200-SSF-N	200	73	87	50	240	140	110	11	105	105	56	156	3600	3000	3250

**RE.F5-FSL-N**

Code	Description	D	d1	d2	I3	H	b3	Rolling resistance# [N]	Dynamic carrying capacity# [N]	⚖️
451851	RE.F5-080-FSL-N	80	73	12	25	107	40	1500	2000	650
451856	RE.F5-100-FSL-N	100	73	12	30	128	35	2250	2000	880
451861	RE.F5-125-FSL-N	125	73	12	35	156	37	2800	2200	1080
451866	RE.F5-150-FSL-N	150	102	20	40	188	56	3300	3000	2200
451871	RE.F5-200-FSL-N	200	102	20	50	236	56	3600	3000	2950

**RE.F5-FSF-N**

Code	Description	D	d1	d2	I3	H	b3	R	Rolling resistance# [N]	Dynamic carrying capacity# [N]	⚖️
451901	RE.F5-080-FSF-N	80	73	12	25	107	40	120	1500	2000	780
451906	RE.F5-100-FSF-N	100	73	12	30	128	35	120	2250	2000	1020
451911	RE.F5-125-FSF-N	125	73	12	35	156	37	120	2800	2200	1230
451916	RE.F5-150-FSF-N	150	102	20	40	188	56	156	3300	3000	2490
451921	RE.F5-200-FSF-N	200	102	20	50	236	56	156	3600	3000	3240

# For rolling resistance and dynamic carrying capacity see Technical data (on page 1296).

