

- 1
- 2
- 3
- 4
- 5
- 6
- 7
- 8
- 9
- 10
- 11
- 12
- 13
- 14
- 15
- 16
- 17
- 18
- 19

BASE

Glass-fibre reinforced polyamide based (PA) technopolymer, black colour, matte finish.

ARTICULATED STEM

Glass-fibre reinforced polyamide based (PA) SUPER-technopolymer, with hexagonal socket and regulation hexagon.

STANDARD EXECUTIONS

- **LV.A-STP**: without no-slip disk.
- **LV.A-AS-STP**: with NBR rubber no-slip disk, hardness 70 Shore A, supplied assembled to the base.

FEATURES

Thanks to the property of the SUPER-technopolymer stem, high rigidity and mechanical resistance are obtained in addition to natural resistance to corrosion.

The special knurling under the lower lip of the base provides excellent stability and grip when using the levelling element without no-slip disk even on surfaces that are not perfectly flat.

The particular assembling system of the no-slip disk to the base assures a perfect anchoring, preventing separation even in case of impact during transport or of adhesion (sticking) to the floor (see No-slip disks on page).

ORDER INFORMATION

The levelling feet are supplied unassembled to make carriage and storage easier. The components (base and stem) are supplied in separate packing: less volume taken and better protection from scratches and dirt.

To order bases and stems separately, see:

- table of possible combinations Bases/Stems (see page 839)
- the codes of the Bases (see page 836)
- the codes of the Stems (see page ...).

ACCESSORIES ON REQUEST

NT. (see page -): AISI 304 stainless steel or zinc-plated steel nut.



ELESA Original design

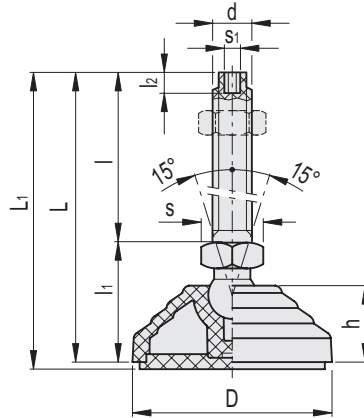

LV.A-AS-STP

Code	Description	D	d	L	L1	l	l1	l2	h	s	s1	Articulation Ø	Max. limit static load* [N]	⚖️
307123	LV.A-60-14-AS-STP-M8x44	60	M8	78.5	81.5	44	34.5	5	24	16	3	14	2700	64
307127	LV.A-60-14-AS-STP-M8x69	60	M8	103.5	106.5	69	34.5	5	24	16	3	14	2700	66
307223	LV.A-60-14-AS-STP-M10x44	60	M10	78.5	81.5	44	34.5	6	24	16	4	14	4800	66
307227	LV.A-60-14-AS-STP-M10x69	60	M10	103.5	106.5	69	34.5	6	24	16	4	14	5000	68
307233	LV.A-60-14-AS-STP-M10x99	60	M10	133.5	136.5	99	34.5	6	24	16	4	14	5100	71
307323	LV.A-60-14-AS-STP-M12x44	60	M12	78.5	81.5	44	34.5	7	24	16	5	14	6800	67
307327	LV.A-60-14-AS-STP-M12x69	60	M12	103.5	106.5	69	34.5	7	24	16	5	14	7000	70
307333	LV.A-60-14-AS-STP-M12x99	60	M12	133.5	136.5	99	34.5	7	24	16	5	14	7000	75
307523	LV.A-60-14-AS-STP-M16x69	60	M16	105.5	108.5	69	36.5	7	24	22	6	14	8000	81
307527	LV.A-60-14-AS-STP-M16x109	60	M16	145.5	148.5	109	36.5	7	24	22	6	14	8000	91
307543	LV.A-60-14-AS-STP-M16x149	60	M16	185.5	188.5	149	36.5	7	24	22	6	14	7000	100
307563	LV.A-60-14-AS-STP-M16x169	60	M16	205.5	208.5	169	36.5	7	24	22	6	14	6000	104
308007	LV.A-70-14-AS-STP-M8x44	70	M8	74.5	77.5	44	30.5	5	19	16	3	14	2700	64
308013	LV.A-70-14-AS-STP-M8x69	70	M8	99.5	102.5	69	30.5	5	19	16	3	14	2700	65
308023	LV.A-70-14-AS-STP-M10x44	70	M10	74.5	77.5	44	30.5	6	19	16	4	14	4800	65
308027	LV.A-70-14-AS-STP-M10x69	70	M10	99.5	102.5	69	30.5	6	19	16	4	14	5000	68
308033	LV.A-70-14-AS-STP-M10x99	70	M10	129.5	132.5	99	30.5	6	19	16	4	14	5100	70
308063	LV.A-70-14-AS-STP-M12x44	70	M12	74.5	77.5	44	30.5	7	19	16	5	14	6800	67
308067	LV.A-70-14-AS-STP-M12x69	70	M12	99.5	102.5	69	30.5	7	19	16	5	14	7000	70
308073	LV.A-70-14-AS-STP-M12x99	70	M12	129.5	132.5	99	30.5	7	19	16	5	14	7000	74
308103	LV.A-70-14-AS-STP-M16x69	70	M16	101.5	104.5	69	32.5	7	19	22	6	14	8000	80
308107	LV.A-70-14-AS-STP-M16x109	70	M16	141.5	144.5	109	32.5	7	19	22	6	14	8000	91
308113	LV.A-70-14-AS-STP-M16x149	70	M16	181.5	184.5	149	32.5	7	19	22	6	14	7000	99
308117	LV.A-70-14-AS-STP-M16x169	70	M16	201.5	204.5	169	32.5	7	19	22	6	14	6000	104
308123	LV.A-80-14-AS-STP-M8x44	80	M8	79.5	82.5	44	35.5	5	24	16	3	14	2700	86
308127	LV.A-80-14-AS-STP-M8x69	80	M8	104.5	107.5	69	35.5	5	24	16	3	14	2700	88
308223	LV.A-80-14-AS-STP-M10x44	80	M10	79.5	82.5	44	35.5	6	24	16	4	14	4800	88
308227	LV.A-80-14-AS-STP-M10x69	80	M10	104.5	107.5	69	35.5	6	24	16	4	14	5000	90
308233	LV.A-80-14-AS-STP-M10x99	80	M10	134.5	137.5	99	35.5	6	24	16	4	14	5100	93
308323	LV.A-80-14-AS-STP-M12x44	80	M12	79.5	82.5	44	35.5	7	24	16	5	14	6800	89
308327	LV.A-80-14-AS-STP-M12x69	80	M12	104.5	107.5	69	35.5	7	24	16	5	14	7000	93
308333	LV.A-80-14-AS-STP-M12x99	80	M12	134.5	137.5	99	35.5	7	24	16	5	14	7000	97
308523	LV.A-80-14-AS-STP-M16x69	80	M16	106.5	109.5	69	37.5	7	24	22	6	14	8000	103
308527	LV.A-80-14-AS-STP-M16x109	80	M16	146.5	149.5	109	37.5	7	24	22	6	14	8000	113
308543	LV.A-80-14-AS-STP-M16x149	80	M16	186.5	189.5	149	37.5	7	24	22	6	14	7000	122
308563	LV.A-80-14-AS-STP-M16x169	80	M16	206.5	209.5	169	37.5	7	24	22	6	14	6000	127
309452	LV.A-100-14-AS-STP-M8x44	100	M8	79	82	44	35	5	24	16	3	14	2700	139
309454	LV.A-100-14-AS-STP-M8x69	100	M8	104	107	69	35	5	24	16	3	14	2700	140
309462	LV.A-100-14-AS-STP-M10x44	100	M10	79	82	44	35	6	24	16	4	14	4800	140
309464	LV.A-100-14-AS-STP-M10x69	100	M10	104	107	69	35	6	24	16	4	14	5000	143
309466	LV.A-100-14-AS-STP-M10x99	100	M10	134	137	99	35	6	24	16	4	14	5100	146
309472	LV.A-100-14-AS-STP-M12x44	100	M12	79	82	44	35	7	24	16	5	14	6800	142
309474	LV.A-100-14-AS-STP-M12x69	100	M12	104	107	69	35	7	24	16	5	14	7000	145
309476	LV.A-100-14-AS-STP-M12x99	100	M12	134	137	99	35	7	24	16	5	14	7000	150
309482	LV.A-100-14-AS-STP-M16x69	100	M16	106	109	69	37	7	24	22	6	14	8000	155
309484	LV.A-100-14-AS-STP-M16x109	100	M16	146	149	109	37	7	24	22	6	14	8000	166
309486	LV.A-100-14-AS-STP-M16x149	100	M16	186	189	149	37	7	24	22	6	14	7000	174
309488	LV.A-100-14-AS-STP-M16x169	100	M16	206	209	169	37	7	24	22	6	14	6000	179

* The max static load is the value above which the load applied to the element may cause some plastic material breakage, in particular conditions of use. Obviously, a factor that takes into consideration the importance and the safety level of the specific application must be applied to this value.



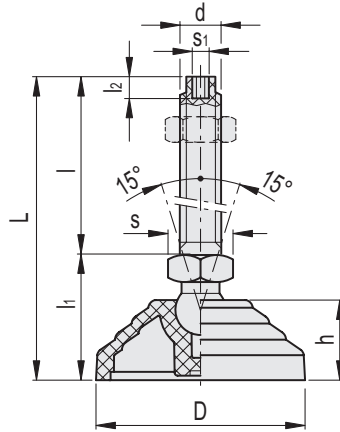
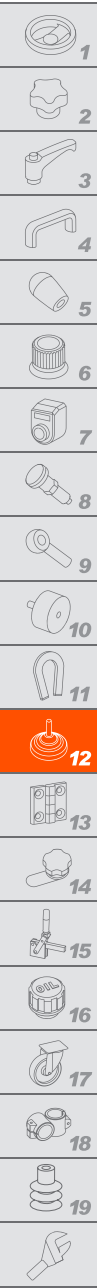

LV.A-STP

Code	Description	D	d	L	l	l1	l2	h	s	s1	Articulation Ø	Max. limit static load* [N]	⚖️
303123	LV.A-60-14-STP-M8x44	60	M8	78.5	44	34.5	5	24	16	3	14	2700	43
303127	LV.A-60-14-STP-M8x69	60	M8	103.5	69	34.5	5	24	16	3	14	2700	44
303223	LV.A-60-14-STP-M10x44	60	M10	78.5	44	34.5	6	24	16	4	14	4800	44
303227	LV.A-60-14-STP-M10x69	60	M10	103.5	69	34.5	6	24	16	4	14	5000	46
303233	LV.A-60-14-STP-M10x99	60	M10	133.5	99	34.5	6	24	16	4	14	5100	49
303323	LV.A-60-14-STP-M12x44	60	M12	78.5	44	34.5	7	24	16	5	14	6800	46
303327	LV.A-60-14-STP-M12x69	60	M12	103.5	69	34.5	7	24	16	5	14	7000	49
303333	LV.A-60-14-STP-M12x99	60	M12	133.5	99	34.5	7	24	16	5	14	7000	53
303523	LV.A-60-14-STP-M16x69	60	M16	105.5	69	36.5	7	24	22	6	14	8000	59
303527	LV.A-60-14-STP-M16x109	60	M16	145.5	109	36.5	7	24	22	6	14	8000	70
303543	LV.A-60-14-STP-M16x149	60	M16	185.5	149	36.5	7	24	22	6	14	7000	78
303563	LV.A-60-14-STP-M16x169	60	M16	205.5	169	36.5	7	24	22	6	14	6000	83
304007	LV.A-70-14-STP-M8x44	70	M8	74.5	44	30.5	5	19	16	3	14	2700	42
304013	LV.A-70-14-STP-M8x69	70	M8	99.5	69	30.5	5	19	16	3	14	2700	44
304023	LV.A-70-14-STP-M10x44	70	M10	74.5	44	30.5	6	19	16	4	14	4800	44
304027	LV.A-70-14-STP-M10x69	70	M10	99.5	69	30.5	6	19	16	4	14	5000	46
304033	LV.A-70-14-STP-M10x99	70	M10	129.5	99	30.5	6	19	16	4	14	5100	49
304063	LV.A-70-14-STP-M12x44	70	M12	74.5	44	30.5	7	19	16	5	14	6800	45
304067	LV.A-70-14-STP-M12x69	70	M12	99.5	69	30.5	7	19	16	5	14	7000	49
304073	LV.A-70-14-STP-M12x99	70	M12	129.5	99	30.5	7	19	16	5	14	7000	53
304103	LV.A-70-14-STP-M16x69	70	M16	101.5	69	32.5	7	19	22	6	14	8000	59
304107	LV.A-70-14-STP-M16x109	70	M16	141.5	109	32.5	7	19	22	6	14	8000	69
304113	LV.A-70-14-STP-M16x149	70	M16	181.5	149	32.5	7	19	22	6	14	7000	78
304117	LV.A-70-14-STP-M16x169	70	M16	201.5	169	32.5	7	19	22	6	14	6000	82
304123	LV.A-80-14-STP-M8x44	80	M8	79.5	44	35.5	5	24	16	3	14	2700	65
304127	LV.A-80-14-STP-M8x69	80	M8	104.5	69	35.5	5	24	16	3	14	2700	66
304223	LV.A-80-14-STP-M10x44	80	M10	79.5	44	35.5	6	24	16	4	14	4800	66
304227	LV.A-80-14-STP-M10x69	80	M10	104.5	69	35.5	6	24	16	4	14	5000	69
304233	LV.A-80-14-STP-M10x99	80	M10	134.5	99	35.5	6	24	16	4	14	5100	72
304323	LV.A-80-14-STP-M12x44	80	M12	79.5	44	35.5	7	24	16	5	14	6800	68
304327	LV.A-80-14-STP-M12x69	80	M12	104.5	69	35.5	7	24	16	5	14	7000	71
304333	LV.A-80-14-STP-M12x99	80	M12	134.5	99	35.5	7	24	16	5	14	7000	76
304523	LV.A-80-14-STP-M16x69	80	M16	106.5	69	37.5	7	24	22	6	14	8000	81
304527	LV.A-80-14-STP-M16x109	80	M16	146.5	109	37.5	7	24	22	6	14	8000	92
304543	LV.A-80-14-STP-M16x149	80	M16	186.5	149	37.5	7	24	22	6	14	7000	100
304563	LV.A-80-14-STP-M16x169	80	M16	206.5	169	37.5	7	24	22	6	14	6000	105
305452	LV.A-100-14-STP-M8x44	100	M8	79	44	35	5	24	16	3	14	2700	97
305455	LV.A-100-14-STP-M8x69	100	M8	104	69	35	5	24	16	3	14	2700	98
305462	LV.A-100-14-STP-M10x44	100	M10	79	44	35	6	24	16	4	14	4800	98
305464	LV.A-100-14-STP-M10x69	100	M10	104	69	35	6	24	16	4	14	5000	101
305467	LV.A-100-14-STP-M10x99	100	M10	134	99	35	6	24	16	4	14	5100	103
305472	LV.A-100-14-STP-M12x44	100	M12	79	44	35	7	24	16	5	14	6800	100
305474	LV.A-100-14-STP-M12x69	100	M12	104	69	35	7	24	16	5	14	7000	103
305476	LV.A-100-14-STP-M12x99	100	M12	134	99	35	7	24	16	5	14	7000	107
305482	LV.A-100-14-STP-M16x69	100	M16	106	69	37	7	24	22	6	14	8000	113
305484	LV.A-100-14-STP-M16x109	100	M16	146	109	37	7	24	22	6	14	8000	124
305486	LV.A-100-14-STP-M16x149	100	M16	186	149	37	7	24	22	6	14	7000	132
305488	LV.A-100-14-STP-M16x169	100	M16	206	169	37	7	24	22	6	14	6000	137

* The max static load is the value above which the load applied to the element may cause some plastic material breakage, in particular conditions of use. Obviously, a factor that takes into consideration the importance and the safety level of the specific application must be applied to this value.