

- 1
- 2
- 3
- 4
- 5
- 6
- 7
- 8
- 9
- 10
- 11
- 12
- 13
- 14
- 15
- 16
- 17
- 18
- 19

**MATERIAL**

Nickel-plated brass

**STANDARD EXECUTIONS**

- **CGM-HR**: metric threadings.
- **CGM-HR-PG**: PG threadings.

**FEATURES AND APPLICATIONS**

They are used to install a cable gland in a mounting hole on electrical equipment that does not match the thread size of the cable gland itself, ensuring mechanical protection and a secure seal. To secure the reducers, use the CGM-NT mounting nut.

**ACCESSORY**

- CGM: cable glands
- CGM-NT: mounting nuts.

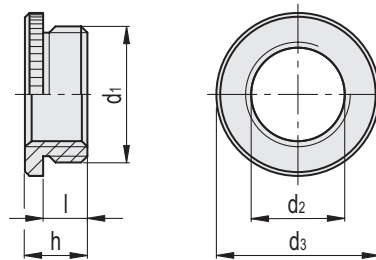
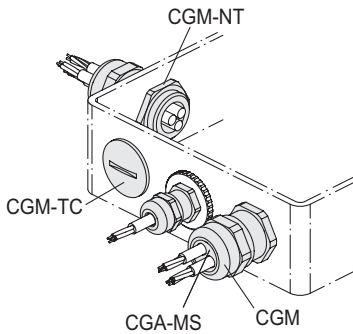

**CGM-HR**

Code	Description	d <sub>1</sub>	d <sub>2</sub>	d <sub>3</sub>	h	l	⚖
560901	CGM-HR-M16-M12-NK	M 16 x 1.5	M 12 x 1.5	20	8	6	8
560903	CGM-HR-M20-M16-NK	M 20 x 1.5	M 16 x 1.5	24	9	6.5	10
560905	CGM-HR-M25-M20-NK	M 25 x 1.5	M 20 x 1.5	30	10	7	18
560907	CGM-HR-M32-M25-NK	M 32 x 1.5	M 25 x 1.5	37	11.5	8	35
560909	CGM-HR-M40-M32-NK	M 40 x 1.5	M 32 x 1.5	43	11.5	8	46
560911	CGM-HR-M50-M40-NK	M 50 x 1.5	M 40 x 1.5	56	14	10	93
560913	CGM-HR-M63-M50-NK	M 63 x 1.5	M 50 x 1.5	66	14	10	124

**CGM-HR-PG**

Code	Description	d <sub>1</sub>	d <sub>2</sub>	d <sub>3</sub>	h	l	⚖
560915	CGM-HR-PG9-PG7-NK	PG 9	PG 7	17	8.5	6	5
560917	CGM-HR-PG11-PG9-NK	PG 11	PG 9	20	8.5	6	7
560919	CGM-HR-PG13.5-PG11-NK	PG 13.5	PG 11	22	9	6.5	5
560921	CGM-HR-PG16-PG13.5-NK	PG 16	PG 13.5	24	9.5	6.5	6
560923	CGM-HR-PG21-PG16-NK	PG 21	PG 16	30	10	7	19
560925	CGM-HR-PG29-PG21-NK	PG 29	PG 21	39	11.5	8	44
560927	CGM-HR-PG36-PG29-NK	PG 36	PG 29	50	12.5	9	70
560929	CGM-HR-PG42-PG36-NK	PG 42	PG 36	57	14	10	68
560931	CGM-HR-PG48-PG42-NK	PG 48	PG 42	64	14	10	64

Standard machine parts