

- 1
- 2
- 3
- 4
- 5
- 6
- 7
- 8
- 9
- 10
- 11
- 12
- 13
- 14
- 15
- 16
- 17
- 18
- 19

**BRACKET**

Glass-fibre reinforced polyamide based (PA) technopolymer, black colour, matte finish.

**CLAMPING HANDWHEEL**

Glass-fibre reinforced technopolymer, black colour, matte finish.

**EYE SCREW AND WASHER**

AISI 304 stainless steel.

**BOSS**

Hexagonal in nickel-plated brass for tightening by means of a key, threaded hole.

**FEATURES AND APPLICATIONS**

Particularly suitable when a linear positioning of the guide rail is required.

The vertical or horizontal positioning of the eye screw improves the assembly where necessary. Maximum tightening torque for screw assembly 39 Nm.

**ACCESSORIES ON REQUEST**

DSG: spacer for guide rail bracket, in glass-fibre reinforced technopolymer, black colour, matte finish.

**ASSEMBLY INSTRUCTION**

- Fit the guide rail bracket (Fig. 1).
- Insert the washer into the eye screw and screw either the knob or the nut (Fig. 2).
- Insert the eye in its housing either in the horizontal or vertical position (Fig. 3).
- Insert the guide pin in its clamping hole, set the linear positioning and then fasten (Fig. 4).

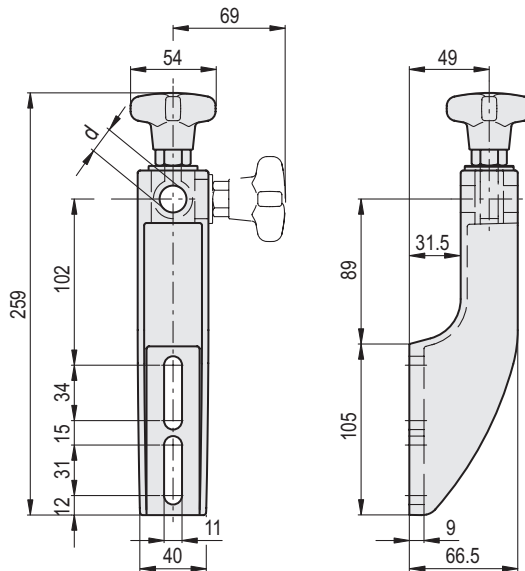
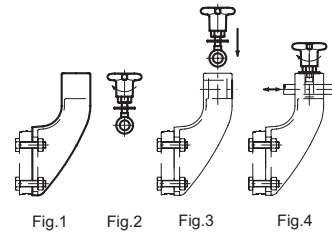

Code	Description	d	Δ
419721	SPFL.V-12	12	256
419722	SPFL.V-14	14	256
419723	SPFL.V-16	16	256