

1	
2	
3	
4	
5	
6	
7	
8	
9	
10	
11	
12	
13	
14	
15	
16	
17	
18	

**MATERIAL**

C10 zinc-plated steel.

**BASE**

C10 zinc-plated steel.

**HEXAGON-SOCKET HEAD SCREWS WITH COUNTERSINK FOR CYLINDER SUPPORT**

Black-oxide steel.

**CYLINDER SUPPORT BUSHINGS**

Hardened steel.

**CYLINDER BODY AND HEADERS**

Aluminium.

**ROTATING PINS AND SEEGER RINGS**

Ground and hardened steel.

**PUSH LEVER**

AISI 420 stainless steel.

**STANDARD EXECUTIONS**

- **PVE-APVS:**  
with open clamping lever and two folded washers.
- **PVE-EPVS:**  
with solid clamping lever and bolt retainer.

**MAXIMUM WORKING PRESSURE**

6 bars.

**MAX WORKING TEMPERATURE**

70°C.

**CLAMPING BOLT**

To be ordered separately.

**FEATURES AND APPLICATIONS**

All articulated joints are lubricated with special grease.  
 PVE. pneumatic clamps can be installed on two different fixing surfaces.  
 They are all equipped with a magnetic cylinder which, through the use of the proximity switch PSWX###PSWX (see page -) (to be ordered separately) gives drive and/or control impulses while active.  
 All magnetic cylinders are equipped with an automatic pneumatic brake in the rear head.  
 Using a lubrication filter assembly is necessary for the cylinder to work properly for a long time, whereas flow regulators are recommended to guarantee long life of mechanical components.

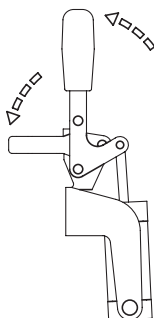



PVE-APVS

PVE-EPVS

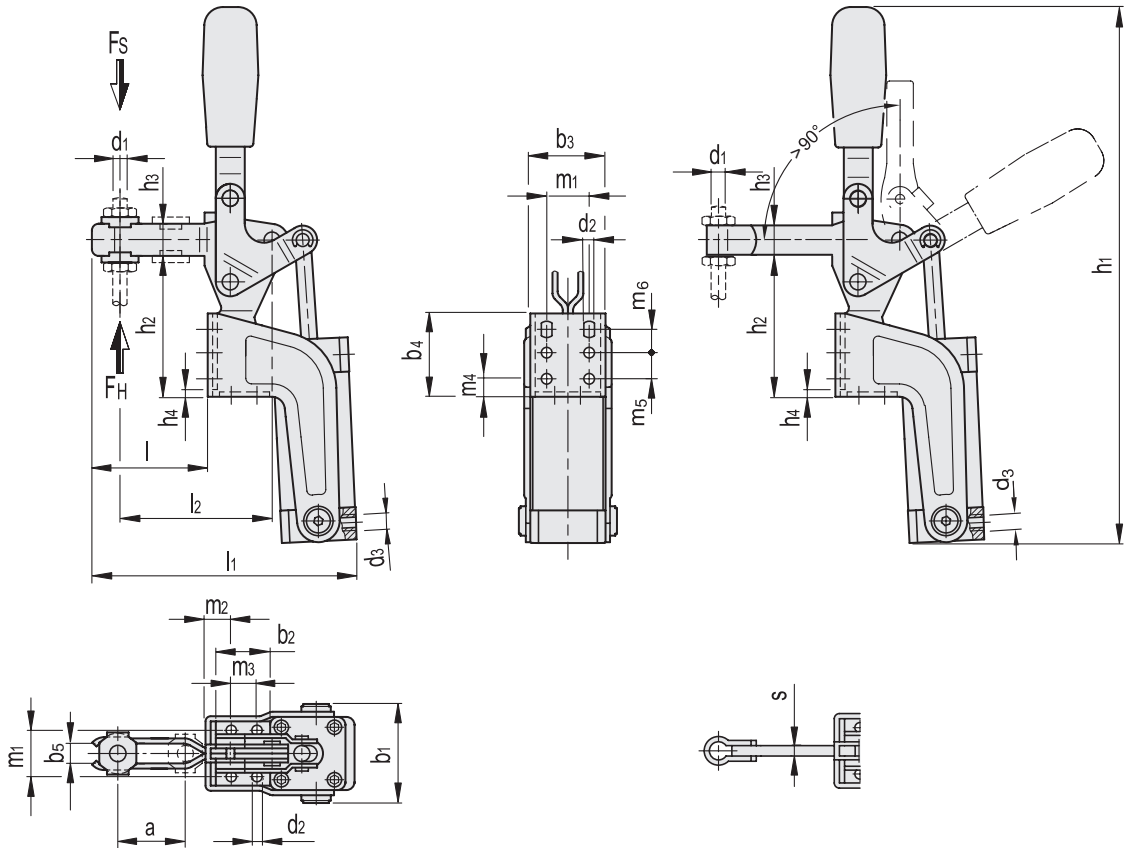

PVE-APVS

Code	Description	a	b1	b2	b3	b4	b5	d1	d2	d3	h1	h2	h3	h4	l	l1	l2	m1	m2	m3	m4	m5	m6	FH* [N]	FS# [N]	⚖
GG.AO424	PVE.230/APVS	41	58	32	46	51	8.5	M8	6.5	G1/8	302	87	18	3	62	153	94.5	26	14	16	11	16	14.2	2200	1260	1350
GG.AO436	PVE.330/APVS	45	70	45	56	79	10.5	M10	8.5	G1/4	363	108	22	3.5	68	182	110	30	16	28	19	30	20	2600	1800	2300

PVE-EPVS

Code	Description	b1	b2	b3	b4	d1	d2	d3	h1	h2	h3	h4	l	l1	m1	m2	m3	m4	m5	m6	s	FH* [N]	FS# [N]	⚖
GG.AO426	PVE.230/EPVS	58	32	46	51	M8	6.5	G1/8	302	87	18	3	63	155	26	14	16	11	16	14.2	6	2200	1260	1400
GG.AO438	PVE.330/EPVS	70	45	56	79	M10	8.5	G1/4	363	108	22	3.5	70	184	30	16	28	19	30	20	7	2600	1800	2300

\* Holding force.  
# Clamping force -6 bar.

