

- 1
- 2
- 3
- 4
- 5
- 6
- 7
- 8
- 9
- 10
- 11
- 12
- 13
- 14
- 15
- 16
- 17
- 18

MATERIAL

Glass-fibre reinforced polyamide based (PA) technopolymer, grey-black colour, matte finish.

STANDARD EXECUTION

Pass-through holes for front or rear mounting by means of cylindrical-head screws with hexagon socket, hexagonal-head screws or nuts.

TECHNICAL DATA

Tensile stress and impact strength: the values F1, F2, L1 and L2 indicated in the table were obtained during breaking tests carried out with the appropriate dynamometric equipment under the test conditions shown in the figure with ambient temperature.

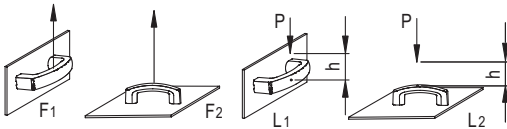

$$L [J] = P [N] \cdot h [m]$$



ELESA Original design

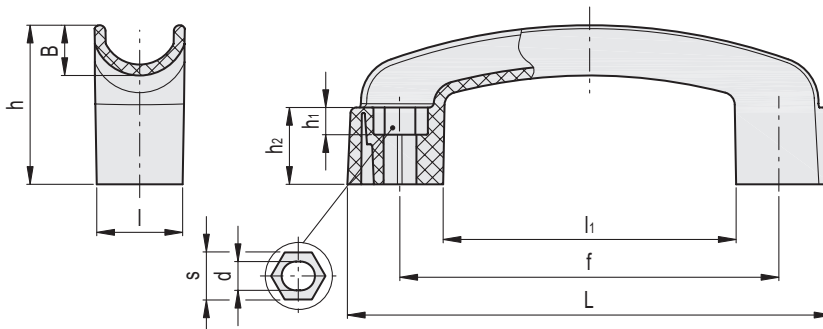

Code	Description	L	l	f±1	d	s	h	h1	h2	B	l1	F1 [N]	F2 [N]	L1 [J]	L2 [J]	
260910	MPC.152-6	153	28	117-120	6.5	10	49.5	6.5	24	15.5	93	2800	2500	10	30	57
260911	MPC.152-8	153	28	117-120	8.5	13	49.5	8.5	24	15.5	93	2800	2500	10	30	54