

- 1
- 2
- 3
- 4
- 5
- 6
- 7
- 8
- 9
- 10
- 11
- 12
- 13
- 14
- 15
- 16
- 17
- 18

### BODY

Transparent polyamide based (PA-T/AR) technopolymer. Highly resistant to shocks, solvents, oils with additives, aliphatic and aromatic hydrocarbons, petrol, naphtha, phosphoric esters, additives and detergents containing alcohol. High UV resistance.

### PROTECTION FRAME

Glass-fibre reinforced polyamide based (PA) SUPER-technopolymer, black colour, matte finish. Supplied assembled, removable by a screw-driver.

### PACKING RINGS

Step-shaped for the seal on the reservoir walls and NBR synthetic rubber O-ring screw underneath. Suggested roughness of the packing ring application surface Ra = 3 µm.

### CONTRAST SCREEN

White lacquered aluminium. The housing, in the appropriate external rear slot, guarantees the best protection from direct contact with fluid. It can be taken out from the inclined side, before assembly to allow the insertion of level lines or words.

### THERMOMETER

Incorporated thermometer for temperature reading.

### STANDARD EXECUTIONS

- **HCZ/T-AR-PT**: zinc-plated steel screws, nuts and washers.
- **HCZ/T-AR-PT-VT**: AISI 303 stainless steel screws, AISI 304 stainless steel nuts and washers.

### MAXIMUM CONTINUOUS WORKING TEMPERATURE

90°C (with oil).

### FEATURES AND PERFORMANCES

- Ultrasound welding to guarantee a perfect seal.
- Maximum fluid level visibility even from side positions.
- Lens effect for a better visibility of the fluid level.
- Thanks to the SUPER-technopolymer screws, HCZ/T-AR-PT-VT column level indicator can be used in corrosion resistance applications where stainless steel is not necessary.
- The special slotted head of the SUPER-technopolymer screws is especially designed to reach an optimum tightening of the packing rings by applying an adequate tightening torque (ELESA patent) thus avoiding unnecessary stress to the screws.

### TECHNICAL DATA

In laboratory tests carried out with mineral oil type CB68 (according to ISO 3498) at 23°C for a limited period of time, the weld stood up to: 13 bar (HCX.76-AR-PT and HCX.127-AR-PT) 10 bar (HCX.254-AR-PT). Considering the SUPER-technopolymer screws, the maximum working pressure cannot be higher than 5 bar at 20°C and 2 bar at 90°C. For use with other fluids and under different pressure and temperature conditions, please contact ELESA Technical Department. In any case we suggest to verify the suitability of the product under the actual working conditions.



ELESA Original design

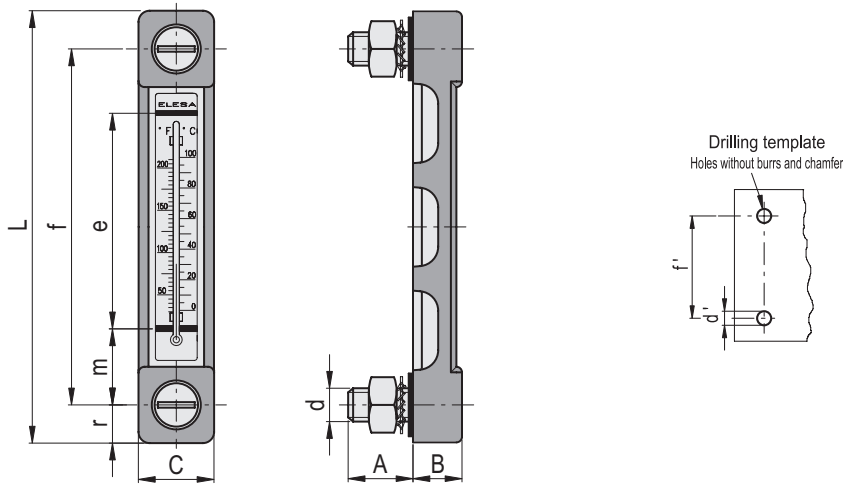

HCZ/T-AR-PT

Code	Description	f	d	A	B	C	L	e	m	r	d'±0.2	f±0.2	Thermometer scale °C	Thermometer scale °F	C# [Nm]	⚖
11393-R	HCZ.76/T-AR-PT-M10	76	M10	22	17.5	27	105	40	18	14.5	10.5	76	20+100	68+210	12	102
11396-R	HCZ.127/T-AR-PT-M12	127	M12	22	17.5	27	156	80	23	14.5	12.5	127	0+100	32+210	12	139
11399-R	HCZ.254/T-AR-PT-M12	254	M12	22	17.5	31	284	203	25	15.5	12.5	254	0+100	32+210	12	150

HCZ/T-AR-PT-VT

Code	Description	f	d	A	B	C	L	e	m	r	d'±0.2	f±0.2	Thermometer scale °C	Thermometer scale °F	C# [Nm]	⚖
11393-R	HCZ.76/T-AR-PT-VT-M12	76	M12	23.5	17.5	27	105	40	18	14.5	12.5	76	20+100	68+210	6	86
11396-R	HCZ.127/T-AR-PT-VT-M12	127	M12	23.5	17.5	27	156	80	23	14.5	12.5	127	0+100	32+210	6	105
11399-R	HCZ.254/T-AR-PT-VT-M12	254	M12	23.5	17.5	31	284	203	25	15.5	12.5	254	0+100	32+210	6	170

# Maximum tightening torque.